

## 1. Module details and its structure

Subject Name	Physics
Course Name	Physics 03 (Physics Part-1, Class XII)
Module Name/Title	Unit- 04, Module- 09: Power transmission in AC Chapter- 07: Alternating Current
Module Id	Leph10706_eContent
Pre-requisites	AC, DC, AC generator, series and parallel circuits, fuse , transformer, characteristics of ac
Objectives	<p>After going through the module the learner will be able to :</p> <ul style="list-style-type: none"> <li>• <b>Appreciate</b> the application of transformers to step up or step down AC</li> <li>• <b>Know</b> about Power transmission from source to our homes and other electricity users</li> <li>• <b>Understand</b> household electrical connections</li> </ul>
Keywords	Transformers, household electricity, primary distribution, secondary distribution ,MCB, Fuse

## 2. Development Team

Role	Name	Affiliation
National MOOC Coordinator / (NMC)	Prof. Amarendra P. Behera	Central Institute of Educational Technology, NCERT, New Delhi
Programme Coordinator	Dr. Mohd Mamur Ali	Central Institute of Educational Technology, NCERT, New Delhi
Course Coordinator / PI	Anuradha Mathur	Central Institute of Educational Technology, NCERT, New Delhi
Subject Matter Expert (SME)	Ramesh Prasad Badoni	GIC Chharba, Dehradun Uttarakhand
Review Team	Associate Prof. N.K. Sehgal (Retd.) Prof. V. B. Bhatia (Retd.) Prof. B. K. Sharma (Retd.)	Delhi University Delhi University DESM, NCERT, New Delhi

## TABLE OF CONTENTS

1. Unit syllabus
2. Module wise distribution of unit syllabus
3. Words you must know
4. Introduction
5. Advantages and disadvantages of AC and DC
6. Distribution of electricity to your home
7. Generation and transmission
8. Primary distribution
9. Secondary distribution
10. Summary

## 1. UNIT SYLLABUS

### Unit IV: Electromagnetic Induction and Alternating Currents

#### Chapter-6: Electromagnetic Induction

Electromagnetic induction; Faraday's laws, induced emf and current; Lenz's Law, Eddy currents; Self and mutual induction.

#### Chapter-7: Alternating Current

Alternating currents, peak and rms value of alternating current/voltage; reactance and impedance; LC oscillations (qualitative treatment only), LCR series circuit, resonance; power in AC circuits, watt-less current; AC generator and transforme

**2. MODULE WISE DISTRIBUTION OF UNIT SYLLABUS**

The above unit is divided into 9 modules for better understanding.

Module 1	<ul style="list-style-type: none"> <li>• Electromagnetic induction</li> <li>• Faraday's laws, induced emf and current;</li> <li>• Change of flux</li> <li>• Rate of change of flux</li> </ul>
Module 2	<ul style="list-style-type: none"> <li>• Lenz's Law,</li> <li>• Conservation of energy</li> <li>• Motional emf</li> </ul>
Module 3	<ul style="list-style-type: none"> <li>• Eddy currents.</li> <li>• Self induction</li> <li>• Mutual induction.</li> <li>• Unit</li> <li>• Numerical</li> </ul>
Module 4	<ul style="list-style-type: none"> <li>• AC generator</li> <li>• Alternating currents,</li> <li>• Representing ac</li> <li>• <i>Formula</i></li> <li>• <i>Graph</i></li> <li>• <i>Phasor</i></li> <li>• Frequency of ac and what does it depend upon</li> <li>• peak and rms value of alternating current/voltage;</li> </ul>
Module 5	<ul style="list-style-type: none"> <li>• ac circuits</li> <li>• components in ac circuits</li> </ul>

	<ul style="list-style-type: none"> <li>• comparison of circuit component in ac circuit with that if used in dc circuit</li> <li>• reactance mathematically</li> <li>• <i>pure R</i></li> <li>• <i>pure L</i></li> <li>• <i>Pure C</i></li> <li>• Phasor, graphs for each</li> </ul>
Module 6	<ul style="list-style-type: none"> <li>• AC circuits with RL, RC and LC components</li> <li>• Using phasor diagram to understand current and voltage phase differences</li> <li>• Impedance; LC oscillations (qualitative treatment only),</li> <li>• Resonance</li> </ul>
Module 7	<ul style="list-style-type: none"> <li>• Alternating voltage applied to series LCR circuit</li> <li>• Impedance in LCR circuit</li> <li>• Phasor diagram</li> <li>• Resonance</li> <li>• Quality Factor</li> <li>• Power in ac circuit</li> <li>• Power factor</li> <li>• Wattles current</li> </ul>
Module 8	<ul style="list-style-type: none"> <li>• Transformer</li> </ul>
Module 9	<ul style="list-style-type: none"> <li>• Advantages of AC over DC</li> <li>• Distribution of electricity to your home</li> </ul>

### MODULE 9

### 3. WORDS YOU MUST KNOW

Let us remember the words we have been using in our study of this physics course:

- **Electromagnetic Induction:** The phenomenon in which electric current can be generated by varying magnetic fields is called electromagnetic induction (EMI).
- **Magnetic flux:** Just like electric flux, magnetic flux  $\Phi_B$  through any surface of area  $A$  held perpendicularly in magnetic field  $B$  is given by the total number of magnetic lines of force crossing the area. Mathematically, it is equal to the dot product of  $B$  and  $A$ .

$$\Phi_B = \mathbf{B} \cdot \mathbf{A} = BA \cos \theta, \text{ where } \theta \text{ is the angle between } B \text{ and } A$$

- **Induced emf and Induced current:** The emf developed in a loop when the magnetic flux linked with it changes with time is called induced emf when the conductor is in the form of a closed loop, the current induced in the loop is called an induced curr

- **Faraday's laws of electromagnetic induction:**

**First law:** It states that whenever the amount of magnetic flux linked with the coil changes with time, an emf is induced in the coil. The induced emf lasts in the coil only as long as the change in the magnetic flux continues.

**Second law:** It states that the magnitude of the emf induced in the coil is directly proportional to the time rate of change of the magnetic flux linked with the coil.

- **Lenz's Law:** The law states that the direction of induced emf is always such that it opposes the change in magnetic flux responsible for its production.
- **Fleming's Right Hand rule:** Fleming's right hand rule gives us the direction of induced emf/current in a conductor moving in a magnetic field .

If we stretch the fore-finger, central finger and thumb of our right hand mutually perpendicular to each other such that fore-finger is in the direction of the field, thumb is in the direction of motion of the conductor, then the central finger would give the direction of the induced current.

❖ **Induced emf by changing the magnetic field:** The movement of magnet or pressing the key of coil results in changing the magnetic field associated with the coil, this induces the emf.

- **Electric Generator:** In electricity generation, a generator is a device that converts mechanical energy to electrical energy for use in an external circuit.
- **Electric Current:** An electric current equals the rate of flow of electric charge. In electric circuits this charge is often carried by moving electrons in a wire. It can also be carried by ions in an electrolyte, or by both ions and electrons such as in plasma. We can have alternating current or direct current
- **Voltage:** Voltage drop, electric potential difference denoted by  $V$  or  $U$ , (for instance in the context of Ohm's or Kirchhoff's laws) is the difference in electric potential energy between two points per unit electric charge. We can have alternating voltage.
- **Eddy Currents:** Eddy currents are loops of electrical current induced within conductors by a changing magnetic field in the conductor, (as per Faraday's law of induction). Eddy currents flow in closed loops within conductors, in planes perpendicular to the magnetic field. They can be induced within (nearby) stationary conductors by a time-varying magnetic field.

- **Capacitor:** A capacitor (originally known as a condenser) is a passive two-terminal electrical component used to store electrical energy temporarily in an electric field.
- **Inductor:** An inductor, also called a coil or reactor, is a passive two-terminal electrical component which resists changes in electric current passing through it.
- **Choke Coil:** a choke is an inductor; it is used to block higher-frequency alternating current (AC) in an electrical circuit, while passing lower-frequency currents or direct current (DC).
- **Watt-less current:** Watt-less current is that AC current, for which the power consumed by the circuit, is zero.
- **Electrical Conductor:** In physics and electrical engineering, a conductor is an object or type of material that allow the flow of electrical current in one or more directions. A metal wire is a common electrical conductor.
- **Electrical Insulator:** An electrical insulator is a material whose internal electric charges do not flow freely, and therefore make it nearly impossible to conduct an electric current under the influence of an electric field.
- **Transformer:** A transformer is an electrical device that transfers electrical energy between two or more circuits through electromagnetic induction.
- **Mutual Induction:** The production of an electromotive force in a circuit by a change in the current in an adjacent circuit which is linked to the first by the flux lines of a magnetic field.

- **Flux leakage:** This flux is called leakage flux which passes through the winding insulation and transformer insulating oil instead of passing through core
- **Hysteresis loss:** It is due to the reversal of magnetization of transformer core whenever it is subjected to alternating nature of magnetizing force
- **Step-Up Transformer:** A transformer that increases voltage from primary to secondary (more secondary winding turns than primary winding turns) is called a step-up transformer.
- **Step-Down Transformer:** A step down transformer has less turns on the secondary coil than the primary coils.

#### 4. INTRODUCTION

We have worked in detail with two types of currents. The Direct current (DC) is the unidirectional flow of electric charge. Direct current is produced by sources such as batteries, power supplies, thermocouples, solar cells, or dynamos designed to obtain DC. AC is commercially generated by rotating a coil in a strong magnetic field. The Alternating Current (AC) is the flow of electric charge periodically reversing its direction, whereas in direct current (DC), the flow of electric charge is only in one direction.

The abbreviations AC and DC are often used to mean simply alternating current /voltage and direct current /voltage.

**Go to**

<http://powermin.nic.in>

**Government of India website of Power Ministry**



**We have included the link in the module so that you get an idea about the demand, production and distribution of electricity in India**

**Excerpt from the website**

The Overall generation (including generation from grid connected renewable sources) in the country has been increased from 1173.458 BU during 2014-15 to 1173.603 BU during the year 2015-16. The Category wise generation performance as follows:-

Thermal Increased by	7.45%
Hydro Reduced by	6.09%
Nuclear Increased by	3.63%
Bhutan Import Increased by	4.72 %
Renewable Increased by	6.47 %

**Overall Growth rate recorded by 5.69 %**

**The annual growth in power generation during recent years is as under:**

YEAR	GROWTH IN CONVENTIONAL GENERATION (%)	GROWTH IN RENEWABLE GENERATION (%)	GROWTH IN TOTAL GENERATION (%)
2008-09	2.7	-	-
2009-10	6.6	-	-
2010-11	5.56	-	-
2011-12	8.11	-	-
2012-13	4.01	-	-
2013-14	6.04	-	-
2014-15	8.43	-	-
2015-16	5.64	6.47	5.69

YEAR	GROWTH IN CONVENTIONAL GENERATION (%)	GROWTH IN RENEWABLE GENERATION (%)	GROWTH IN TOTAL GENERATION (%)
2016-17	4.59	26.54	5.83

\*Up to February 2017 **check out the updated data**

### ISO 14001

Established in November 1975 for nation's Sustainable Power Development, National Thermal Power Corporation Ltd. (NTPC) is today India's largest power utility with an installed capacity of 21,749 MW (19% of India's installed capacity) contributing to 26% of total generation in the country, with high availability factor of its power plants. NTPC has plans to double its capacity. NTPC has recently diversified into the hydro sector and formed for joint venture companies for distribution, R&M, etc. Environment Management is a high priority area in the company and several Policies have been formulated to ensure generation of green power. Through persuasion of sound environmental management systems and practices, NTPC's 18 stations have been accredited with ISO: 14001 certification. As a responsible corporate citizen, NTPC is a member of Global Compact a UN initiative for corporate social responsibility.

The focus and emphasis in future in the company will be on generation of power in line with global standards and in complete harmony with the environment and nature.

### Production %

- **Coal:** 189,047.88 MW (**59.9%**)
- **Large Hydro:** 44,413.43 MW (**14.1%**)
- **Small Hydro:** 4,333.86 MW (**1.4%**)
- **Wind Power:** 28,700.44 MW (**9.1%**)
- **Biomass:** 7,971.02 MW (**2.5%**)
- **Solar Power:** 9,012.69 MW (**2.9%**)

- **Gas:** 25,329.38 MW (8.0%)
- **Nuclear:** 5,780 MW (1.8%)
- **Diesel:** 837.63 MW (0.3%)

### **TRANSMISSION FROM POWER PLANTS TO OUR HOMES ( Wikipedia)**

[https://en.wikipedia.org/wiki/Electricity\\_sector\\_in\\_India#Electricity\\_transmission\\_and\\_distribution](https://en.wikipedia.org/wiki/Electricity_sector_in_India#Electricity_transmission_and_distribution)

#### **The data is old but will give you an idea**

The spread of high voltage (HV) transmission lines is such that it can form a square matrix of area  $416 \text{ km}^2$  (i.e. on average, at least one HV line within 10.2 km distance/vicinity) in entire area of the country.

The length of high-voltage transmission lines is nearly equal to that of the United States (322,000 km of 230 kV and above) but transmits far less electricity. The HV transmission lines (132 kV and above) installed in the country is nearly 700,000 km (i.e. on average, at least one  $\geq 13 \text{ kV}$  transmission line within 4.5 km distance).

The length of transmission lines (400 V and above and excluding 220 V lines) is 10,558,177 km as on 31 March 2015 in the country. The spread of total transmission lines ( $\geq 400 \text{ V}$ ) is such that it can form a square matrix of area  $36.8 \text{ km}^2$  (i.e. on average, at least one transmission line within 3 km distance) in entire area of the country.

The all-time maximum peak load is not exceeding 158,713 MW in the unified grid whereas the all-time peak load met is 156,058 MW on 9 September 2016. The maximum achieved demand factor of substations is not exceeding 60% at 200 kV level.

The operational performance of the huge capacity substations and the vast network of high voltage transmission lines with low demand factor is not satisfactory in meeting the peak electricity load.

India's Aggregate Transmission and Commercial (ATC) loss is 27% in 2011-12. The Government has pegged the national ATC losses at around 24% for the year 2011 & has set a target of reducing them to 17.1% by 2017 & to 14.1% by 2022.

**A high proportion of non-technical losses are caused by**

- ✓ **illegal tapping of lines, and**
- ✓ **Faulty electric meters that underestimate actual consumption also contribute to reduced payment collection.**

A case study in Kerala estimated that replacing faulty meters could reduce distribution losses from 34% to 29%.

**In this module we will study a little about transmission and house hold circuitry**

### **5. ADVANTAGES AND DISADVANTAGES OF AC AND DC**

AC	DC
<p><b>Advantage</b></p> <ul style="list-style-type: none"> <li>• it loses far less power over long electrical lines</li> <li>• it is the most used system as a result</li> <li>• given that it's the standard system used in electrical mains power, it is the most practical system to adopt in the domestic electricity system as well</li> <li>• Although power can be generated</li> </ul>	<p><b>Advantage</b></p> <ul style="list-style-type: none"> <li>• Capacitance and Inductance are not used as resistive devices, so capacitive leakage and inductive impedance will be absent.</li> <li>• Due to tremendous progress in DC-DC converters, it's economical to go for High Voltage DC and heat losses can be drastically reduced.</li> <li>• The advantages are that DC voltage</li> </ul>

<p>completely off-grid, there is an advantage to transferring/sell off surplus electricity to the national power companies; i.e. via net metering. Adopting AC power as the standard, allows the use of less equipment (i.e. power inverter), also there is no 10% power loss due to the use of this inverter.</p> <ul style="list-style-type: none"> <li>• Power lines can be thinner to than comparable DC lines. In practice, i.e. 12 gauge AC wire can be used, while 10 gauge DC wire would be required. When extrapolating the wiring problem into practice i.e. in a lightning situation, we see that on AC, 8 lights can be powered, and only 3 on DC</li> </ul> <p><b>Disadvantages</b></p> <ul style="list-style-type: none"> <li>• One negative side of AC power is that many different standards have developed around the world. AC power can run at</li> </ul>	<p>can be created directly onsite with solar panels. If you are generating DC power for use in your home you can use DC directly as it is. You can use DC motors for all the appliances like refrigerators etc.</p> <ul style="list-style-type: none"> <li>• Most of electric power consumed in DC. Electric Motor, heating element, electronics, Electric Car and virtually all electrical machineries consumes electricity in DC. Even some highly efficient 3 phase AC electric motor cannot compete with (Brushed or even brush-less) DC Motor in terms of efficiency and simplicity.</li> </ul> <p><b>Disadvantages:</b></p> <ul style="list-style-type: none"> <li>• If you need to connect the HVDC (high voltage DC) to an AC grid, it becomes really complex.</li> <li>• Now that DC-DC converter is</li> </ul>
--	--

various frequencies.. The "standard" type to use is 230V/50Hz, which is more efficient but more dangerous than the 110 V 60 Hz used in the USA. Caution is always needed with electricity, and the higher the voltage, the more important are safety measures.

- Delivering electrical current as alternating current (AC) is that any electrical equipment which needs direct current (DC) cannot run on it. In order to run such equipment, the AC has to be rectified to convert it to DC.

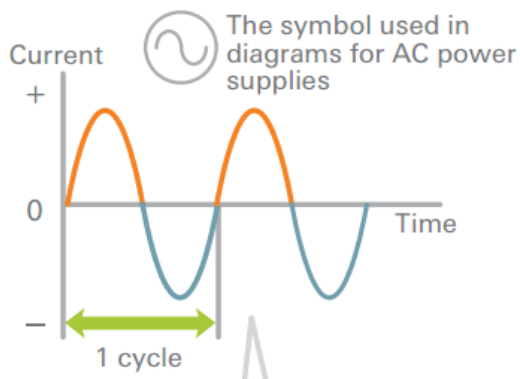

becoming more and more efficient and inexpensive

- For smaller networks, HVDC becomes really expensive compared to HV AC.
- DC is not easily transmitted far distances. It was for this reason that the entire electrical grid was built with AC because it can be transformed up and then down so sending it long distances is easy.

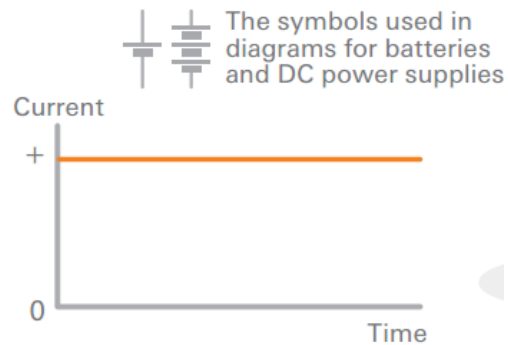

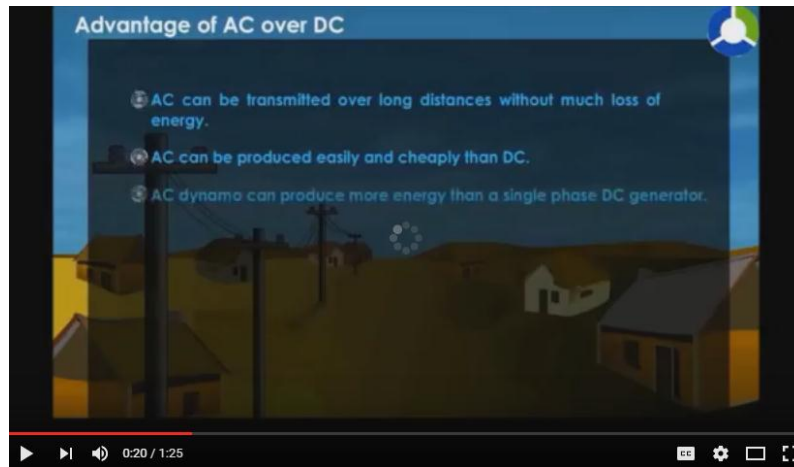

<https://www.youtube.com/watch?v=TfpI4Er41Ds>

**Review previous modules-link to previous:**

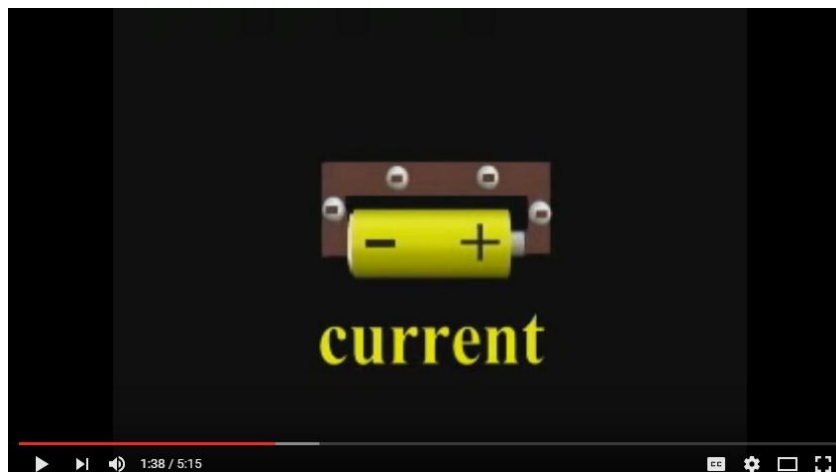

<https://www.youtube.com/watch?v=EJeAuQ7pkpc>



<https://www.youtube.com/watch?v=g17f9J1-r-k>

for more:

[https://www.google.co.in/url?sa=i&rct=j&q=&esrc=s&source=images&cd=&cad=rja&uact=8&ved=0ahUKEwin1qWYws3NAhVGQo8KHYGXA0IQjRwIBw&url=https%3A%2F%2Fen.wikipedia.org%2Fwiki%2FPhotovoltaic\\_system&bvm=bv.125801520,d.c2I&psig=AFQjCNFW3waTztfJPZgJ9bfmVx4x\\_sj86g&ust=1467298855961927](https://www.google.co.in/url?sa=i&rct=j&q=&esrc=s&source=images&cd=&cad=rja&uact=8&ved=0ahUKEwin1qWYws3NAhVGQo8KHYGXA0IQjRwIBw&url=https%3A%2F%2Fen.wikipedia.org%2Fwiki%2FPhotovoltaic_system&bvm=bv.125801520,d.c2I&psig=AFQjCNFW3waTztfJPZgJ9bfmVx4x_sj86g&ust=1467298855961927)

<https://www.youtube.com/watch?v=pXasvq1ivnw>

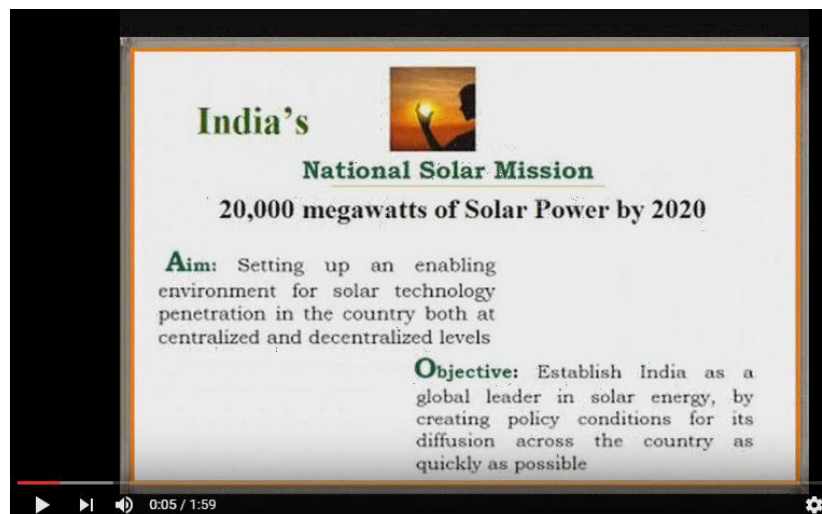

<https://www.youtube.com/watch?v=BP-5QWifB4E>



## 6. DISTRIBUTION OF ELECTRICITY TO YOUR HOME

**An electric power distribution system is the final stage in the delivery of electric power; it carries electricity from the transmission system to individual consumers.**

Distribution substations connect to the transmission system and lower the transmission voltage to medium voltage ranging between 2 kV and 35 kV with the use of transformers.

Primary distribution lines carry this medium voltage power to distribution transformers located near the customer's premises.

Distribution transformers again lower the voltage to the utilization voltage of household appliances and typically feed several customers through *secondary* distribution lines at this voltage.

Commercial and residential customers are connected to the secondary distribution lines through service drops.

Customers demanding a much larger amount of power may be connected directly to the primary distribution level or the sub transmission level.

In the first half of the 20th century, the electric power industry was vertically integrated, meaning that one company did generation, transmission, distribution, metering and billing. Starting in the 1970s and 1980s nations began the process of deregulation and privatization, leading to electricity markets.

## GENERATION AND TRANSMISSION

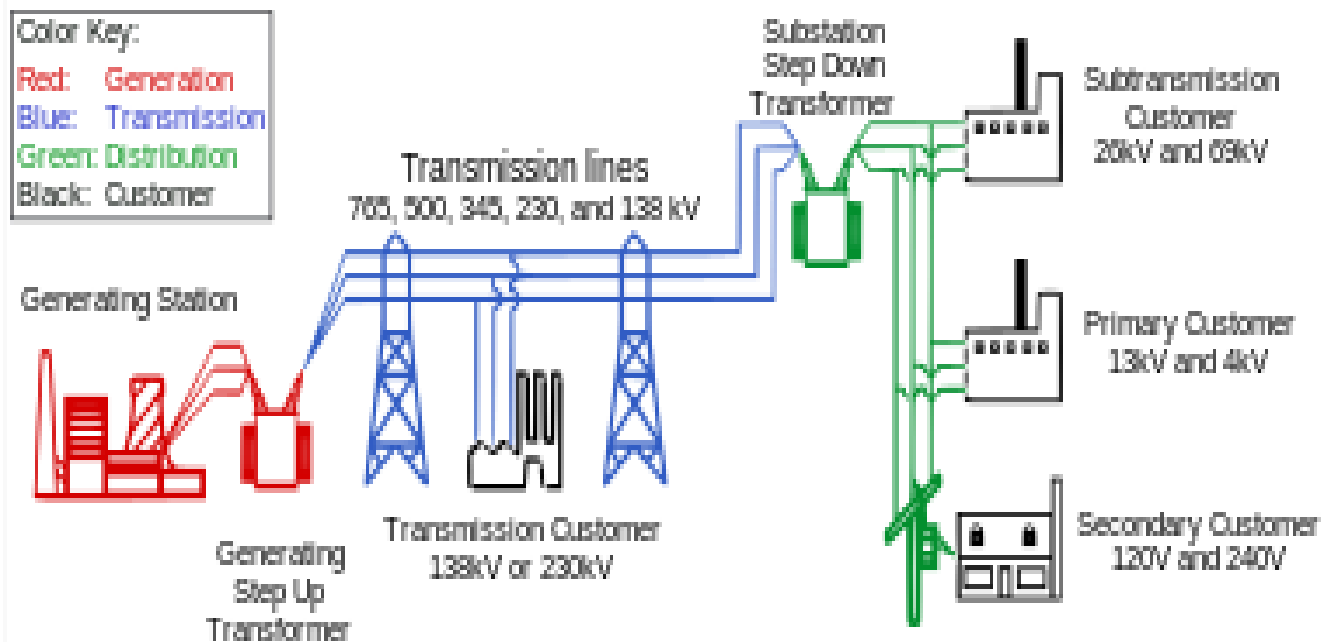

### AC electricity delivery from generation stations to consumers

Electric power begins at a generating station, where the potential difference can be as high as approximately **15,000 volts. AC is usually used.**

Users of large amounts of DC power like railway, telephone exchanges and industrial units .

From the generating station it goes to the generating station's switchyard where a step-up transformer increases the voltage to a level suitable for transmission, from approximately 44,000 to 765,000 volts. Once in the transmission system, electricity from each generating station is combined with electricity produced elsewhere. Electricity is consumed as soon as it is produced. It is transmitted at a very high speed, close to the speed of light.

### 7. PRIMARY DISTRIBUTION

Primary distribution voltages are 22kV or 11 kV. Only large consumers are fed directly from distribution voltages; most utility customers are connected to a transformer, which reduces the distribution voltage to the low voltage used by lighting and interior wiring systems.

According to international standards, there are initially two voltage groups:

- **Low voltage (LV): up to and including 1,000 V AC (or 1,500 V DC)**
- **High voltage (HV): above 1 kV AC (or 1.5 kV DC).**

Distribution networks are divided into two types,

- **Radial network**
- **Spot networks**

**A radial system is arranged like a tree where each customer has one source of supply. A network system has multiple sources of supply operating in parallel.**

**Spot networks are used for concentrated loads.**

Radial systems are commonly used in rural or suburban areas. It may be acceptable to close a loop for a short time depending upon demand or production drop .

Rural services normally try to minimize the number of poles and wires. Single-wire earth return (SWER) is the least expensive, with one wire. It uses higher voltages (than urban distribution), which in turn permits use of **galvanized steel wire**. The strong steel wire allows for less expensive wide pole spacing. In rural areas a pole-mount transformer may serve only one customer. You may have seen these.

Higher voltage split-phase or three phase service, at a higher infrastructure and a higher cost, provide increased equipment efficiency and lower energy cost for commercial use.

## **8. SECONDARY DISTRIBUTION**

Electricity is delivered at a frequency of either 50 Hz, in India It is delivered to domestic customers as single-phase electric power. Seen in an oscilloscope, the domestic power supply in India would look like a sine wave, oscillating between -310 volts and 310 volts (peak values), giving an effective voltage (rms value) of 220 volts.

Three-phase power is more efficient in terms of power delivered per cable used,

A **ground** connection is normally provided for the customer's system as well as for the equipment owned by the supply company .

The purpose of connecting the customer's system to ground is to limit the voltage that may develop if high voltage conductors

Earthing systems employ **thick aluminum or good conductor alloys which do not rust , a thick copper plates that are imbedded in the ground** , the earthing wires are connected to wall sockets . the plugs from the devices have the thick pin which connects the device to the home/commercial establishment earthing

<https://www.slideshare.net/biswajitcet13/electrical-grounding-and-earthing-systems>

### **220-240 volt systems**

Most of the world uses 50 Hz single-phase 220 or 230 V residential and light industrial service. In this system, the primary distribution network supplies a few substations per area, and the 230 V power from each substation is directly distributed.

**A live wire and neutral are connected to the building from one phase of three phase service.**

Single-phase distribution is used where motor loads are light. In Europe, electricity is normally distributed for industry and domestic use by the three-phase, four wire system. Large industrial customers have their own transformers with an input from 10 kV to 220 kV.

### **110-120 volt systems**

Most of the United States uses 60 Hz AC, the 120/240 volt split phase system domestically and three phase for larger installations. Compared to European systems, North American ones have more step-down transformers near customers. This is because the higher domestic voltage used in Europe and Asia (230 V vs 120 V) may be carried over a greater distance with acceptable power loss.

**EXPLORE MORE**

2) **AC can cause the heart to go into fibrillation** : a condition characterized by an irregular and often rapid heart rate that commonly causes poor blood flow to the body. During atrial fibrillation, the heart's two upper chambers (the atria) beat chaotically and irregularly — out of coordination with the two lower chambers (the ventricles) of the heart.

*AC's alternating nature has a greater tendency to throw the heart's pacemaker neurons into a condition of fibrillation, whereas DC tends to just make the heart stand still. Once the shock current is halted, a "frozen" heart has a better chance of regaining a normal beat pattern than a fibrillating heart.*

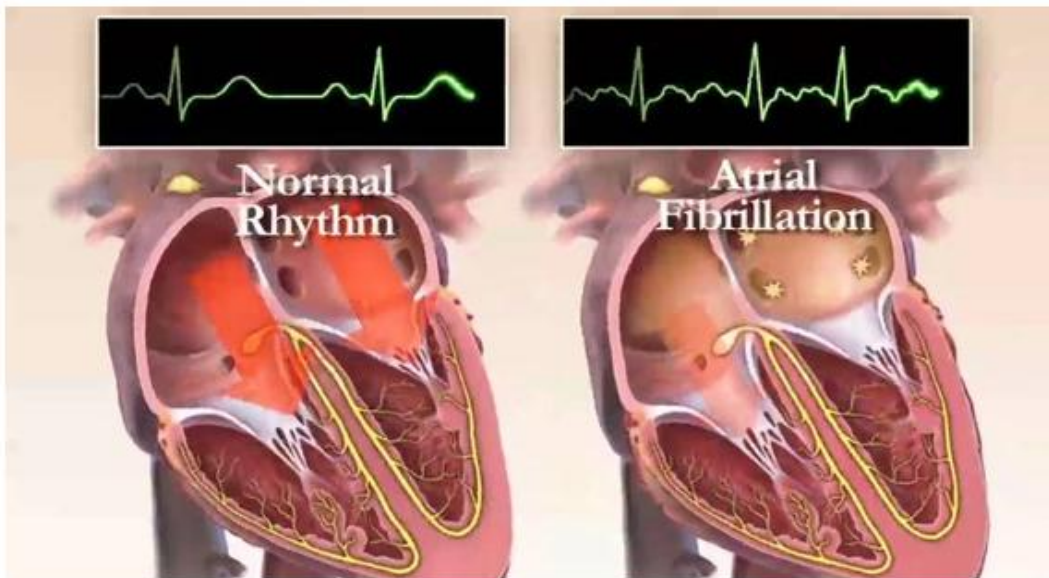

<https://www.quora.com/Which-is-more-dangerous-AC-or-DC-power>

**CONCEPTUAL AND GENERAL AWARENESS BASED QUESTIONS:**

- i. Which one of the two is more dangerous? AC or DC power?
- ii. It is comparatively easier to let go of the gripped 'live' wires in the case of DC than AC. This is in contrary to popular belief. Why?
- iii. Can transformation action take place with DC?
- iv. Why do we use AC at all ?
- v. Do power outlets at home use AC or DC?

- vi. With today's technology, would DC current be a better, more efficient source of electricity than AC?
- vii. Would DC be better than AC to power the modern house?
- viii. Why do we do AC and DC analysis?
- ix. What are the dangers of an electric shock from both a 240 volt AC mains supply and 240 volt DC voltages?
- x. Which current is more useful, an alternating current supply or direct current supply? Why?
- xi. Why is the use of AC current so prevalent in households as opposed to DC power?
- xii. Is lightning AC or DC?
- xiii. Are wall sockets at home AC or DC?
- xiv. Mobiles are charged by ac or dc?
- xv. When and why is DC used instead of AC for long-distance electric power lines?
- xvi. Which is more likely to emit an electromagnetic wave, a wire carrying AC or DC power? And why?
- xvii. What are the advantages of an AC over a DC in power transmission?
- xviii. Why do we not convert DC to AC when using solar power?
- xix. Which is preferred, AC or DC for supplying power to electric trains?
- xx. "War of Currents" is the term used for competition between AC and DC, comment?

## 9. HOUSEHOLD CIRCUITS

In a house, there are many electrical appliances that have to run independent of each other. If one appliance is turned on or off it should not affect the other appliances. This is not possible if all the appliances were connected in a series arrangement as there would be one switch that either switches all of them on or off.

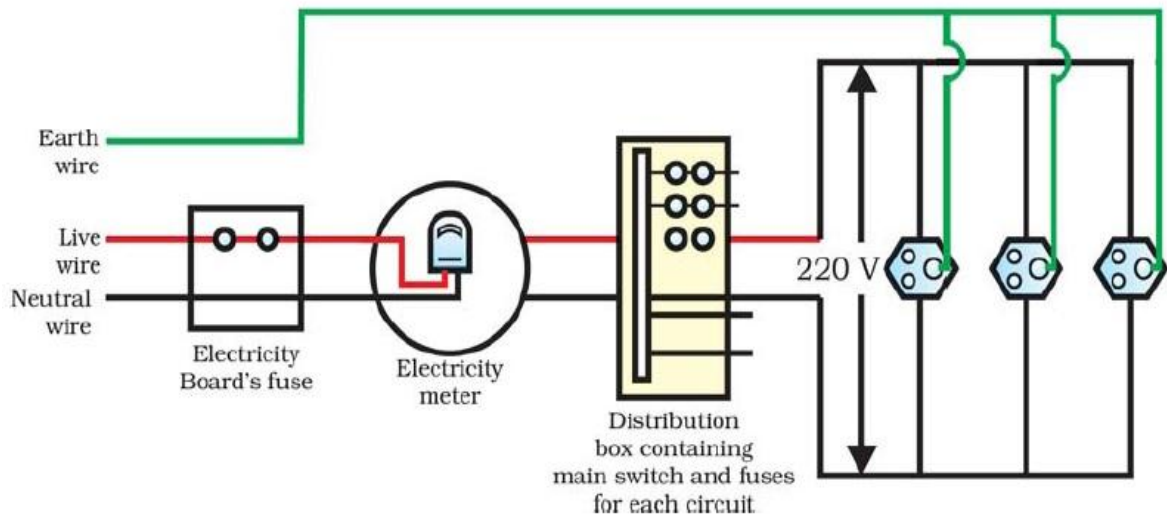

- Electricity from power substation comes by two wires, live wire and neutral wire.

The transformers at the substation reduce the high voltage from the power station to 220V-240V. The three wires may be connected to household by underground or overhead connection for safety and ease of repair.

- Household circuit consists of three wires: live wire (red in color), neutral wire (black), and earth wire (green).
- The green wire is embedded in the earth for earthing
- Earth wire is used for safety purposes, any current leaked into or from the appliances flows harmlessly to the earth.
- **All appliances are connected in parallel to each other.** This ensures independent operation for each device with the help of dedicated switches and connecting wires.

Each appliance has a separate switch, separate connecting wires for individual appliance circuit providing same potential difference

**i). In parallel circuit, if one electrical appliance stops working due to some defect, then all other appliances keeps working normally.**

**ii). In parallel circuits, each electrical appliance has its own switch due to which it can be turned on or turned off independently.**

**iii). In parallel circuits, each electrical appliance gets the same voltage (220V) as that of the power supply line.**

**iv). In the parallel connection of electrical appliances, the overall resistance of the household circuit is reduced due to which the current from the power supply is high.**

- A fuse or an MCB to break or switch off the circuit whenever there is overloading is placed in series with the devices. It is possible that two or more devices use the same fuse.

When an electric current is passed through a metallic wire, the wire gets heated up. Why the wire gets heated up? This is due to heating effect of electric current.

The amount of heat produced in the wire depends on three factors

- ✓ The amount of current passing through the wire
- ✓ The resistance of the wire
- ✓ The time for which current is passed in the wire

- Electrical meters: a device that measures the electrical consumption in a household

Electrical energy consumed is measured by meter in a unit called B.O.T (Board of trade) unit or Kilowatt hour (KWh). 1 unit = 1 KWh

$$1 \text{ KWh} = 3600000 \text{ joule} = 3.6 \times 10^6 \text{ J}$$

- Payment for electricity consumed is done on the basis of how many units are consumed in a certain duration and the price per unit. **You have learnt this in your earlier science courses.**



**FUSE**

**A device that switches off the circuit the instant current exceeds a certain value.**

Fuse is an application of Joule's heating effect of current. It protects circuits and appliances by stopping the flow of any unduly high electric current.

**The fuse is placed in series with the device.**

It consists of a piece of wire made of a metal or an alloy of appropriate melting point, for example aluminium, copper, iron, lead etc.

If a current larger than the specified value flows through the circuit, the temperature of the fuse wire increases. This melts the fuse wire and breaks the circuit.

The fuse wire is usually encased in a cartridge of porcelain or similar material with metal ends.

The fuses used for domestic purposes are rated as **1 A, 2 A, 3 A, 5 A, 10 A, 15 A** etc

. For an electric iron/ electric press which consumes 1 kW electric power when operated at 220 V, a current of  $(1000/220)$  A, that is, 4.54 A will flow in the circuit. In this case, a 5 A wire must be used with the electric iron

Current can rise in circuits due to following reasons:

- **Overloading (too many higher power appliances turned on)**
- **Short circuiting (live wire and neutral wire joined together )**
- **Fluctuation in supply voltage**

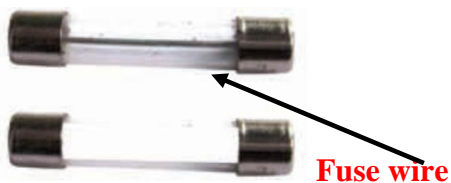

**Glass fuse**

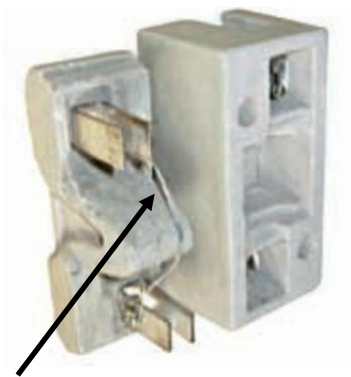

**Fuse wire**

### **Ceramic/porcelain fuse**

### **ALTERNATIVE TO FUSE – THE MCB**

All **fuse wires** need to be replaced manually when they have operated which is not desirable, because both location of fuse circuit and its replacement has to be done by pulling out the plug and checking the fuse wire.

Unlike a fuse, an MCB operates as automatic switch that opens in case of excessive current flowing through the circuit and once the circuit returns to normal, it can be closed without any manual replacement.

### **MCB MEANING:**

MCBs are used primarily as an alternative to the fuse switch in most of the circuits. A wide variety of MCBs have been in use nowadays with breaking capacity of 10KA to 16 KA, in all areas of domestic, commercial and industrial applications as a reliable means of protection.

You may come across:

**MCB – magnetic circuit breaker**

**MCB -miniature circuit breaker**

From the outside it looks like this



[https://commons.wikimedia.org/wiki/File:Four\\_1\\_pole\\_circuit\\_breakers\\_fitted\\_in\\_a\\_meter\\_box.jpg](https://commons.wikimedia.org/wiki/File:Four_1_pole_circuit_breakers_fitted_in_a_meter_box.jpg)



<https://commons.wikimedia.org/wiki/File:Jtecul.jpg>

### HOW does an MCB work?

If circuit is overloaded for long time, the bi - metallic strip becomes over heated and deformed.

The screenshot shows a YouTube video player. The video title is "Heating a Bimetallic Strip" by Prabhat Saxena. The video content shows a bimetallic strip being heated by a Bunsen burner, causing it to bend upwards. The video player interface includes a search bar with "bimetallic strip,creativecommons", a "Sign in" button, and a list of "Up next" videos. The Windows taskbar at the bottom shows the time as 12:57 PM on 3/27/2017.

<https://www.youtube.com/watch?v=9AWKkTPqrJE>

video shows the bending of a bimetallic strip when heated, this is due to dissimilar coefficient of linear expansion of different metals to the same change in temperature.

### Construction of MCB

This deformation of bi metallic strip causes displacement of latch point.

The moving contact of the MCB is so arranged by means of a spring, with this latch point, that a little displacement of latch causes, release of spring and makes the moving contact to move for opening the MCB.

An MCB embodies complete enclosure in a moulded insulating material. This provides mechanically strong and insulated housing. The switching system consists of a fixed and a moving contact to which incoming and outgoing wires are connected. The metal or current

carrying parts are made up of electrolytic copper or silver alloy depending on the rating of the circuit breaker.

<https://www.electrical4u.com/miniature-circuit-breaker-or-mcb/>

### The video shows the working of a MCB

A typical external appearance of an MCB is shown in figure.

MCBs are used to perform many functions such as local control switches, isolating switches against faults and overload protection for equipments or appliances.

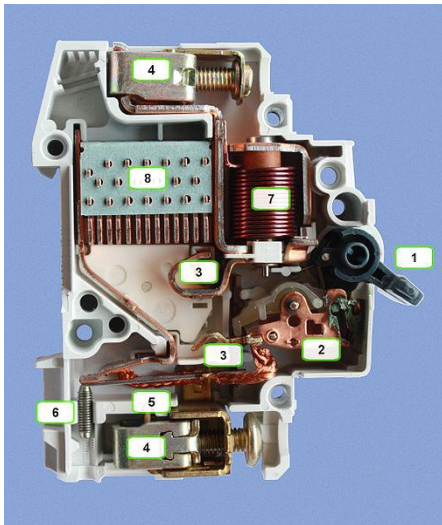

The points shown in figure (a) are depicted as:

- 1: operating lever
- 2: operating mechanism
- 3. Above one is fixed contact and below one is moving contact
- 4: Upper terminal (incoming supply) and lower terminal (outgoing supply or load)
- 5. Bi-metallic strip
- 6: Latch point
- 7: Electro-magnetic protection (solenoid or magnetic coil)
- 8: Arc chamber

[https://commons.wikimedia.org/wiki/File:MCB\\_Hager\\_C10.jpg](https://commons.wikimedia.org/wiki/File:MCB_Hager_C10.jpg)

The thermal tripping arrangement consists of a bimetallic strip around which a heater coil is wound to create heat depending on the flow of current. The heater design can be either direct where current is passed through bimetal strip which effect part of **electric circuit** or indirect where a coil of current carrying conductor is wound around the bimetallic strip.

The deflection of bimetallic strip activates the tripping mechanism in case of certain overload conditions.

The bimetal strips are made up of two different metals, usually brass and steel. These metals are riveted and welded along their length. These are so designed such that they will not heat the strip to the tripping point for normal currents, but if the current is increased beyond rated value, strip is warmed, bent and trips the latch. Bimetallic strips are chosen to provide particular time delays under certain overloads.

## 10. SUMMARY

In this module you have learnt that alternating voltage is developed at the power station. It is transmitted through electrical wiring at a high voltage keeping the current low in order to limit losses due to heat; the voltage is reduced by using transformers at the substation. The supply of 220-240V 50 Hz AC is supplied by two wires at a point called mains to every household.

Each home has its electricity meter to know of the electrical energy used, a fuse /MCB to shut the circuit in case there is an overload or high current inside the appliance or wiring in the circuit.

All appliances are connected in parallel so that operating voltage for each is maintained, switch for each appliance is separate so one can operate them by choice

- **Earthing system:** In electricity supply systems, an earthing system or grounding system is circuitry which connects parts of the electric circuit with the ground
- **HVDC:** High-voltage direct current (HVDC) is used to transmit large amounts of power over long distances or for interconnections between asynchronous grids

- **Transformers:** A transformer is an electrical device that transfers electrical energy between two or more circuits through electromagnetic induction
- **Power generator:** A generator is a device that converts mechanical energy to electrical energy for use in an external circuit.
- **Transmission system:** At a generating plant, electric power is “stepped up” to several thousand volts by a transformer and delivered to the transmission line Transformers.