

1. Module detail and its structure

Subject Name	Physics
Course Name	Physics (Physics Part 1 Class XII)
Module Name/Title	Unit-02, Module-08: Electrical energy and power Chapter-03: Current Electricity
Module Id	Leph_10308_eContent
Pre-requisites	Electrical circuits, resistances in series and parallel, Wheatstone bridge, potentiometer, electrical energy, house hold electricity ,
Objectives	After going through this module the learners will be able to : Apply principles of electrical circuits to solve numerical problems
Keywords	Electrical energy , power, household electricity

2. Development Team

Role	Name	Affiliation
National MOOC Coordinator (NMC)	Prof. Amarendra P. Behera	Central Institute of Educational Technology, NCERT, New Delhi
Programme Coordinator	Dr. Mohd Mamur Ali	Central Institute of Educational Technology, NCERT, New Delhi
Course Coordinator / PI	Anuradha Mathur	Central Institute of Educational Technology, NCERT, New Delhi
Subject Matter Expert (SME)	Dinesh Tyagi	Air Force School Hindan, Ghaziabad, U.P.
Review Team	Associate Prof. N.K. Sehgal (Retd.) Prof. V. B. Bhatia (Retd.) Prof. B. K. Sharma (Retd.)	Delhi University Delhi University DESM, NCERT, New Delhi

TABLE OF CONTENT

1. Unit Syllabus
2. Module wise distribution of unit syllabus
3. Words you must know
4. Introduction
5. Household electricity
6. Rated power and instantaneous power
7. Power in series and parallel
8. Solved example
9. Questions for practice
10. Summary

1. UNIT SYLLABUS:-

Electric current, flow of electric charges in a metallic conductor, drift velocity and mobility, and their relation with electric current; Ohm's law' electrical resistance, V-I characteristics (linear & non-linear), electrical energy and power, electrical resistivity and conductivity.

Carbon resistors, colour code for carbon resistors; series and parallel combinations of resistors; temperature dependence of resistance

Internal resistance of a cell, potential difference and emf of cell, combination of cells in series and in parallel.

Kirchhoff's laws and simple applications; Wheatstone bridge, Metre bridge.

Potentiometer- principle and its applications to measure potential difference & for comparing emf of two cells; measurement of internal resistance of a cell.

2. MODULE WISE DISTRIBUTION OF UNIT SYLLABUS 8 MODULES

The above unit has been divided into 8 modules for better understanding.

Module 1	<ul style="list-style-type: none"> • Electric current, • Solids liquids and gases • Need for charge carriers speed of charge carriers in a metallic conductor • flow of electric charges in a metallic conductor • drift velocity, • mobility and their relation with electric current • Ohm's law,
Module 2	<ul style="list-style-type: none"> • Electrical resistance, • V-I characteristics (linear and non-linear), • Electrical energy and power, • Electrical resistivity and conductivity • Temperature dependence of resistance
Module 3	<ul style="list-style-type: none"> • . Carbon resistors, • Colour code for carbon resistors; • Metallic Wire resistances • Series and parallel combinations of resistors • Grouping of resistances • Current and potential differences in series and parallel circuits
Module 4	<ul style="list-style-type: none"> • Internal resistance of a cell, • Potential difference and emf of a cell, • Combination of cells in series and in parallel. • Need for combination of cells

Module 5	<ul style="list-style-type: none"> • Kirchoff's Rules • Simple applications. of Kirchoff's Rules for calculating current s and voltages <p>Numerical</p>
Module 6	<ul style="list-style-type: none"> • Wheat stone bridge • Balanced Wheatstone bridge condition derivation using Kirchoff's Rules • Wheatstone bridge and Metre Bridge. • Application of meter bridge
Module 7	<ul style="list-style-type: none"> • Potentiometer – • Principle • Applications to • Measure potential difference • Comparing emf of two cells; • Measurement of internal resistance of a cell. <p>Numerical</p>
Module 8	<ul style="list-style-type: none"> • Numerical • Electrical energy and power

Module 8

3. WORDS YOU MUST KNOW

- **Electrical circuit:** It is the arrangement of electrical devices like resistance, cell, etc. to achieve a purpose /objective.

- **Resistance:** Resistance is basically obstruction in path of flow of current. It controls the amount of flow (current) by dropping potential (pressure) across it. It is due to collision of electrons with atom/ions within conductor.
- **Resistivity (ρ):** It is the resistance of a metallic cube of side 1m. It is defined as the resistance of a conductor of length 1m & cross-sectional area 1m^2 .
- **Conductivity(σ):** It is the reciprocal of resistivity
- **Series combination:** combination of resistances such that

$$R_{eq} = R_1 + R_2 + R_3$$
 - Same current flows through each resistor.
 - Potential drops across each resistor are different
- **Parallel combination of resistances:** When all devices have same potential difference, it is said to be a parallel combination.
 - Same potential drop across each resistance.
 - Different currents in each resistor
 - $1/R_{eq} = 1/R_1 + 1/R_2 + 1/R_3$
 - Value of R_{eq} in parallel is less than the least resistor in the group.
- **Thermal Coefficient of Resistance(α):** It is the fractional change in resistance per unit change in temperature
- **Potential drop across resistance:** It is the potential difference between ends of a resistance. In Ohm's law $V = IR$ where, V is potential drop across resistance
- **Ohms law:** Ohms law establishes relationship among potential difference, current and resistance. It states the current flowing through a conductor is directly proportional to the potential difference across it, provided the physical conditions(temperature, composition , pressure) remain the same.

- **Energy:** It is defined as the ability to do work. More is the work done more is the energy. Electrical energy is defined as work done in moving a unit positive charge through a potential difference of one volt.

$$w = q\Delta V$$

- **Power:** It is defined as rate of doing work.

$$P = w/t$$

4. INTRODUCTION

You must have seen a bulb marked as 60W-220V. What does this statement mean?

It means the bulb will consume 60W of power when subjected to 220 V. How much power will it consume if subjected to 110 V?

The monthly electricity bill sent at your home by the electricity department is based on the electrical energy consumed in that particular month.

In this module we will learn more about house hold electricity, transmission, connections and safety measures at home. we will also learn about how we pay for electricity.

5. HOUSEHOLD ELECTRICITY

You must have experienced when current flows through a conductor for some time, the wire gets heated. Ever thought why is it so?

When current flows through a conductor, electrons collide with atoms/ions and transfer their energy to atoms. Due to these collisions a lot of energy is dissipated (wasted) in form of heat which is why the wire gets heated up. The rate of dissipation of this energy is called power.

Let us now derive an expression for power

Let charge q is taken from point A to point B in a conductor, then work done

$$W = q \Delta V$$

$$W = q (V_B - V_A) \text{ or } = q V$$

$$\text{Power, } P = \frac{W}{t} = \frac{\text{electrical work done}}{\text{time}}$$

$$P = \frac{q \Delta V}{t} = V I$$

$$I = \frac{q}{t}$$

Using Ohm's law , $V = IR$, we get

$$P = I^2 R = \frac{V^2}{R}$$

As the **power loss** (“ohmic loss”) in a conductor of resistance R carrying a current I .

Where does this power come from?

As we have reasoned before, we need an external source to keep a steady current through the conductor. It is clearly this source which must supply this power. It is the chemical energy of the cell which supplies this power for as long as it can.

Consider a device R , to which a power P is to be delivered via transmission cables having a resistance R_c to be dissipated by it finally. If V is the voltage across R and I the current through it, then

$$P = VI$$

The connecting wires from the power station to the device have a finite resistance R_c . The power dissipated in the connecting wires, which is wasted is P_c with

$$P_c = I^2 R_c$$

$$P_c = P^2 R_c / V^2$$

$$P_c \propto 1 / V^2$$

Note, here P is the power delivered and P_c is the power wasted.

To save current carrying wires from excessive heat and to minimize the power loss, long distance transmission of electrical power is done at “high voltage, low current”.

Heat developed in a conductor

Heat dissipated = power x time

$$H = I^2 R t$$

OHM'S LAW (FOR REVIEW AND RECALL)

Ohms law establishes relationship among potential difference, current and resistance.

It states that the potential difference between the ends of a conductor is directly proportional to the current flowing through it, provided temperature remains constant.

$$V \propto I$$

$$V = IR$$

Where R is resistance of conductor which is constant for given conditions.

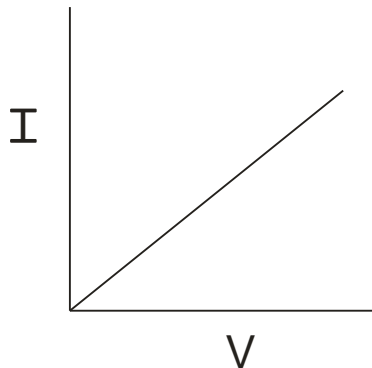

Resistance of a conductor is

- i) directly proportional to length of conductor $R \propto l$
- ii) inversely proportional to area of cross-section $R \propto 1/A$

Resistance $R = \rho \frac{l}{A}$ where ρ = specific resistance/resistivity

Factors affecting value of R:-

- a) **Dimensions of conductor**
- b) **Nature of material of conductor**

Resistance of a given conductor is not fixed or constant as it depends upon dimensions of conductors.

There are two ways to combine resistances

- i) **In series**
- ii) **In parallel**

Resistances in Series



The characteristics of series combination are as follows

- i) **Same current flows through each resistor.**
- ii) **Potential drops, across different resistors, are different.**

$$\text{across } R_1 = I V_1$$

$$\text{across } R_2 = I V_2$$

$$\text{across } R_3 = I V_3$$

- iii) **The combined resistance is larger than the largest resistance in series**

$$V = V_1 + V_2 + V_3$$

$$V = IR_1 + IR_2 + IR_3$$

$$V = I(R_1 + R_2 + R_3)$$

$$V / I = R_1 + R_2 + R_3$$

The expression for equivalent Resistance (R_{eq}) can be written as

$$R_{eq} = R_1 + R_2 + R_3$$

For n resistances in series

$$R_{eq} = R_1 + R_2 + \dots + R_n$$

The value of R_{eq} in a series combination is larger than the largest resistor of the group.

Resistances in Parallel

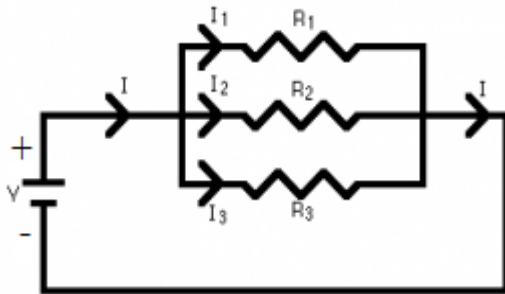

Characteristics of parallel combination of resistances

- Same potential drop across each resistance.
- Different currents in each resistor

Expression for Equivalent Resistance (R_{eq}) (Starts from variable quantity)

$$I = I_1 + I_2 + I_3$$

$$= V / R_1 + V / R_2 + V / R_3$$

$$I = V(1/R_1 + 1/R_2 + 1/R_3)$$

$$1/R_{eq} = 1/R_1 + 1/R_2 + 1/R_3$$

Value of R_{eq} in parallel is less than the least resistor in the group.

For example - Suppose we have 3 resistances 1Ω , 2Ω and 3Ω connected in parallel than value of R_{eq} will be less than 1Ω

Significance of equivalent resistance

An equivalent resistance or resultant resistance is that single resistance which draws the same current from the cell as being drawn by given resistances together from the same cell.

Need for series and parallel resistance combination

- In series net or equivalent resistance increases and hence current drawn from cell decreases. In parallel net or equivalent resistance decreases and hence current drawn from cell increases.

Example: We have 3 resistances 1Ω , 2Ω , 3Ω and a battery of $12V$. If maximum current is to be drawn from cell then resistances should be connected in parallel.

To draw minimum current from the cell resistances should be connected in series.

- In series, failure of one device(resistance) stops working of other devices(resistances)
In parallel, failure of one device (resistance) does not affect working of other devices (resistances).

Example: Whenever there are fluctuations in household voltage, the fuse is burnt due to heavy voltage and the heavy current is not passed to household devices. The failure of fuse stops (saves) household devices, so fuse is put in series with the household circuit.

In household failure of one device should not affect working of other devices so they are connected in parallel.

- In series, as equivalent resistance increases therefore potential drop across the resistance increases, provided current from cell remains constant.

In parallel, as equivalent resistance decreases therefore, for constant current, potential drop across resistance will decrease.

7. In household electricity, the electrical devices are connected in parallel for the following reasons: -

- (i) Failure of one device does not affect working of the other device.
- (ii) All devices are at the same potential difference
- (iii) In parallel, the equivalent resistance is very small so heat losses (energy losses) reduces.
- **Resistance of a device is always constant (within its operating range of temperature variations) because it is fixed by the manufacturer.**
- **A bulb rated as 100W-220 V means the bulb will dissipate (consume) 100 W of electrical power when subjected to 220V. If it is subjected to 110 V, it will dissipate less power.**

Resistance of this bulb is given by $P = \frac{V^2}{R}$

$$R = \frac{V^2}{P}$$

$$R = \frac{220 \times 220}{100}$$

$$R = 484\Omega$$

This resistance will remain constant wherever you put this bulb.

- **A high wattage device has smaller resistance than a device of low wattage.**

EXAMPLE: A 200 W bulb and 100 W bulb, are connected in a house. the supply is at 220 V. find the resistance of each bulb

SOLUTION:

For 200 W bulb resistance $R_1 = \frac{V^2}{P_1}$

For 100W resistance $R_2 = \frac{V^2}{P_2}$

$$R_1 = \frac{220 \times 220}{200}$$

$$R_2 = \frac{220 \times 220}{100}$$

$$R_1 = 242\Omega$$

$$R_2 = 484\Omega$$

Note the resistance of higher wattage bulb is less than a smaller wattage bulb . we can say resistance of 60 W bulb is less than the resistance of 40 W bulb.

The question is in reference to filament type bulb which is almost obsolete now as you now have CFL and LED bulbs.

But you have devices at home which are marked as 220 V 700W for electric iron, or 220V 1000W for toaster you may calculate the resistance of the filament in these cases.

6.RATED POWER AND INSTANTANEOUS POWER

Rated power is the marked power on the device when subjected to a particular voltage.

Instantaneous power is the power dissipated at a given instant of time or situation.

EXAMPLE:

A bulb marked as 60W-220V is subjected to 200 V. Find the power consumed?

SOLUTION:

60 W is the rated power and the power consumed when subjected to 200 V is the instantaneous power. Now let us find the instantaneous power.

$$\text{We know } P = \frac{V^2}{R}$$

$$\text{Rated power, } 60 = \frac{220 \times 220}{R}$$

R remains constant

$$\text{Instantaneous power, } P = \frac{200 \times 200}{R}$$

$$\therefore \frac{60}{P} = \frac{220 \times 220}{200 \times 200}$$

$$P = \frac{60 \times 121}{100}$$

$$\mathbf{P = 49.8W}$$

$$P = I^2 R$$

In series I is constant, so instantaneous power $\propto R$.

$$P = \frac{V^2}{R}$$

In parallel V is constant,

\therefore Instantaneous power $\propto \frac{1}{R}$, no wonder the bulbs glow dimmer when there is a drop in voltage (**fluctuation in supply voltage to the home**)

EXAMPLE:

100W and 200W bulb are connected in

- (i) Series
- (ii) Parallel

Which bulb dissipates more power?

SOLUTION:

Resistance of higher wattage device is smaller than low wattage device therefore so resistance of 200W is smaller than 100 W.

In series, instantaneous power $\propto R$, therefore 100 W bulb will glow brighter or will dissipate more power.

In parallel,

Instantaneous power $\propto \frac{1}{R}$

Therefore 200W will glow brighter or will dissipate more power.

7, POWER IN SERIES AND PARALLEL

equivalent instantaneous power of devices

- i) **Connected in series**
- ii) **Connected In parallel**

Case 1: Let P_1, P_2, P_3 be the rated powers of electrical devices connected in **SERIES**. If

R_1, R_2, R_3 are their resistances, then

$$R_1 = V^2/P_1, \quad R_2 = V^2/P_2 \quad \text{and} \quad R_3 = V^2/P_3$$

When the electrical appliances are connected in series, then effective resistance, R is

$$R = R_1 + R_2 + R_3 \quad \text{Or}$$

Dividing equation by V^2 to convert in power form

$$R/V^2 = R_1/V^2 + R_2/V^2 + R_3/V^2$$

$$1/V^2/R = 1/V^2/R_1 + 1/V^2/R_2 + 1/V^2/R_3$$

Or

$$\frac{1}{P_{eq}} = \frac{1}{P_1} + \frac{1}{P_2} + \frac{1}{P_3}$$

Equivalent instantaneous power is less than the least rated power of the group.

Case 2 Let P_1, P_2, P_3 be the rated powers of electrical devices connected in **PARALLEL**. If R_1, R_2, R_3 are their resistances, then according to law of resistances in parallel,

$$\frac{1}{R} = \frac{1}{R_1} + \frac{1}{R_2} + \frac{1}{R_3}$$

Multiplying both sides by V^2 , we get

$$\frac{V^2}{R} = \frac{V^2}{R_1} + \frac{V^2}{R_2} + \frac{V^2}{R_3}$$

Or

$$\mathbf{P_{eq} = P_1 + P_2 + P_3} \quad \text{as} \quad \frac{V^2}{R} = P$$

Equivalent instantaneous power is greater than the largest rated power in the group

FIVE IMPORTANT APPLICATIONS

Using the rules of series parallel combination and our knowledge of electrical energy and power

i) Finding resistance of a galvanometer by half deflection method

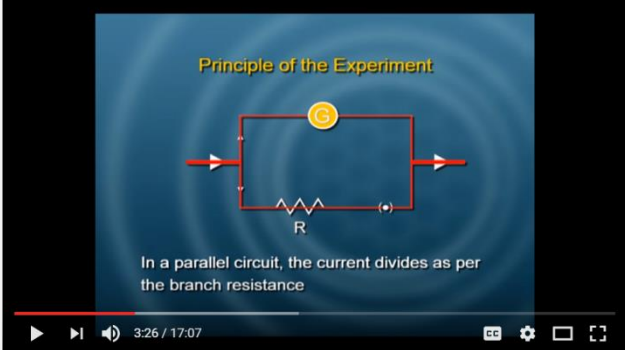

The screenshot shows a YouTube video player with the following details:

- Browser tabs: Physics Activities upload..., Current Electricity 104 - Y...
- URL: <https://www.youtube.com/watch?v=iLigd1Jwa44&feature=youtu.be>
- YouTube logo and search bar.
- Video title: Current Electricity 104
- Channel: NCERT OFFICIAL
- Subscribed status: Subscribed
- View count: 1.54k

<https://www.youtube.com/watch?v=iLigd1Jwa44&feature=youtu.be>

Watch the video to see,

if the current in the parallel branches of a circuit is the same then the resistances should be equal

ii) Household circuits

- All appliances are connected in parallel such that damage to one does not affect the other.
- Each device has a separate switch in the branch resistance
- The supply voltage is same for each device so that they run on optimum efficiency
- Separate fuse may be placed for each circuit called MCB (miniature circuit breaker (You will learn more about MCB in a later module in unit 4 of this course)

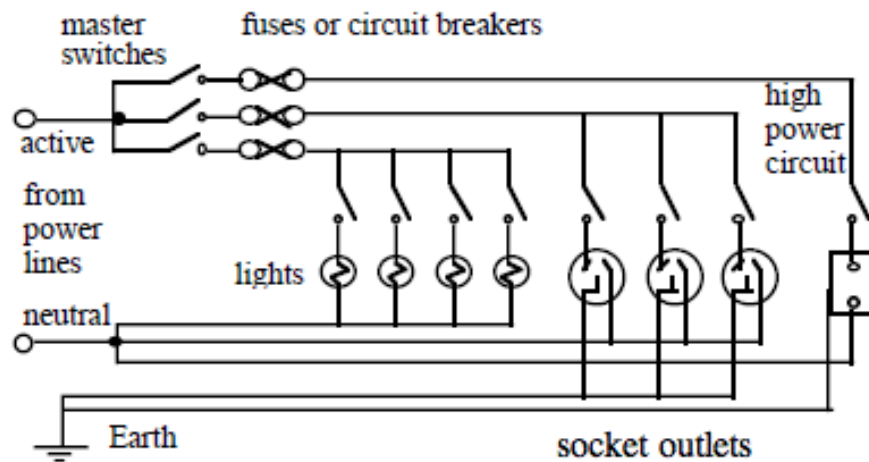

<https://www.animations.physics.unsw.edu.au/jw/electrical-safety.htm>

iii). Power transmission is done at high voltage –

The electricity is produced at power generation plants- thermal, hydro, wind energy nuclear etc . The voltage is stepped up or increased to reduce losses due to heat produced in the transmission lines(wires). **When transformers step up the voltage the corresponding currents are lowered. This reduces transmission losses as heat energy (you will learn more about it the modules that follow in the course)**

iv). CFL and LED

consume very little power giving a large light output. they should be used in order to reduce power consumption and decrease household electricity bills

v) Fuse wires

Fuse is a piece of wire of a material with a very low melting point. When a high current flows through the circuit due to Overloading or a Short circuit, the wires gets heated and melts. The material used for making fuse have low melting points, hence fuse wires are mainly made up of **tin, lead or zinc**. It must be remembered that fuse wire is always connected to the LIVE wire.

8. SOLVED EXAMPLES**EXAMPLE**

A current in a circuit having constant resistance is tripled. How does this affect the power dissipation?

SOLUTION:

The power dissipated in a circuit is $P=I^2R$. Thus, $P \propto I^2$, where R is constant. When I becomes 3 times, P becomes 9 times, i.e. Power dissipation becomes 9 times.

EXAMPLE

What is the power transferred per unit volume into joule heat in a resistor?

SOLUTION:

$$\text{Power, } P = I^2R = I^2\rho l/A$$

$$\text{Volume of resistor, } V = Al$$

$$\text{Therefore, power transferred per unit volume } = \frac{P}{V} = \frac{I^2\rho l/A}{Al} = \left[\frac{I}{A}\right]^2 \rho = J^2\rho$$

Where $I/A = j =$ current density

EXAMPLE

Long distance power transmission is carried on high voltage lines. Why?

SOLUTION

When current I is transmitted through a power line of resistance R .

$$\text{Power loss} = I^2 R$$

If the power p is transmitted at voltage V , then $P = VI$ or $I = (p/V)$

$$\text{Therefore, Power loss} = \left(\frac{P}{V}\right)^2 R$$

For a given power and given line voltage, P and R are constant. Hence, power loss $\propto (I/V^2)$.

It means if power is transmitted at high voltage, power loss will be small and vice-versa.

EXAMPLE

Two bulbs are marked (a) 100W, 220V (b) 40W, 220V. Which has higher resistance? Also, calculate the maximum current that can flow through each bulb.

SOLUTION:

$$V_1 = 220V, P_1 = 100W, V_2 = 220V, P_2 = 40W$$

$$(a) \quad P_1 = V_1 I_1$$

$$I_1 = \frac{P_1}{V_1} = 100/220 = 0.4545A$$

$$R_1 = V^1/I^1 = \frac{220}{0.4545} = 484 \text{ ohm}$$

$$(b) \quad P_2 = V_2 I_2$$

$$I_2 = P_2/V_2 = \frac{40}{220} = 0.1818A$$

$$R_2 = V_2/I_2 = \frac{220}{0.1818} = 1210 \text{ ohm}$$

EXAMPLE:

Current 2A is flowing through a conductor of resistance 4Ω. Find the electrical energy consumed in 10 s.

SOLUTION: -

$$I = 2\text{A}, \quad R = 4\Omega, \quad \Delta t = 10\text{s}$$

$$\begin{aligned} \text{Electrical energy } \Delta W &= I^2 R \Delta t \\ &= 2^2 \times 4 \times 10 \text{ J} \\ &= 160 \text{ J} \end{aligned}$$

EXAMPLE

A wire connected to a bulb does not glow, whereas the filament of the bulb glows when same current flows through them. Why?

SOLUTION:

The heat developed in a resistor by passing current I for time t is given by

$$H = I^2 R t$$

Resistance of connecting wires is very small but resistance of filament is very very high. Therefore, the heat produced in a filament is very high.

9. QUESTIONS FOR PRACTICE

- i) **An electric bulb marked 40W and 200V, is used in a circuit of supply voltage 100V. What is its power?**
- ii) **Three bulbs of 40 W 60 W and 100 W are arranged in series with 220V. Which bulb has minimum resistance?**

- iii) A 30V, 90W lamp is to be operated on a 120 V DC lines. For proper glow, how much resistance (in Ω) should be connected in series with the lamp?
- iv) A heater coil connected across a given potential difference has power P. Now, the coil is cut into two equal halves and joined in parallel. Across the same potential difference, what is the combination power?
- v) A 500W heating device is designed to operate on a 220V line. If the line voltage drops to 220V, find the percentage drop in heat output.
- vi) Two bulbs rated 25W – 220V and 100W – 220V are connected in series to a 440V supply. Show with necessary calculations which bulb is any will fuse?
- vii) What should happen if the two bulbs were connected in parallel to the same supply?
- viii) If two bulbs of wattage 25w and 100W respectively each rated at 220V connected in series with the supply of 440V, which bulb will fuse?
- ix) A wire connected to a bulb does not glow, whereas the filament of the bulb glows when same current flows through them. Why?
- x) Water boils in an electric kettle in 15 minutes after switching on. If the length of the heating wire is decreased to $\frac{2}{3}$ of its initial value, then in how much time the same amount of water will boil with the same supply voltage.

ANSWERS

- (i) 10W
 (ii) 100W
 (iii)30
 (iv)4P

(v) 17.36%

(vi) Let i_1 & i_2 be the maximum allowed currents in the two bulbs and R_1 , R_2 their respective resistances.

$$\text{i. } \therefore R_1 = \frac{220 \times 220}{25} = 1936 \Omega$$

$$\text{ii. } i_1 = \frac{P_1}{V} = \frac{25}{220} = 0.114 \text{ A}$$

$$\text{iii. } R_2 = \frac{220^2}{100} = 484 \Omega$$

$$\text{iv. } i_2 = \frac{P_2}{V} = \frac{100}{220} = 0.454 \text{ A}$$

(vii) When bulbs are connected in series, net resistance

$$\text{i. } R_S = R_1 + R_2 = 1936 + 484 = 2420 \Omega$$

ii. \therefore current in the circuit,

$$\text{iii. } i = \frac{V'}{R_S} = \frac{440}{2420} = 0.18 \text{ A}$$

iv. It means a current of 0.18A passes through both the bulbs connected in series. By comparing this value of current with the value of i_1 & i_2 , we note that $i > i_1$ but less than i_2 . It shows 25W bulb will fuse.

(viii) When bulbs are connected in parallel, let the currents through I and II bulbs be i_1' and i_2' . In parallel combination the voltage across each bulb is the same.

$$\text{i. } \therefore i_1' = \frac{440}{R_1} = \frac{440}{1936} = 0.23 \text{ A}$$

$$\text{ii. And } i_2' = \frac{440}{R_2} = \frac{440}{484} = 0.91 \text{ A}$$

iii. As $i_1' > i_1$ and $i_2' > i_2$, hence in this case both the bulbs will fuse.

(ix) 25W bulb

(x) $H = I^2Rt$

- i. The resistance of connecting wires is negligibly small as compared to the resistance of filament is very high. Therefore, the heat produced in the filament is very large.

(xi) 10 minutes

11. SUMMARY

In this module we have learnt

- Potential drop is potential difference between the ends of a conductor.
- Work is to be done in carrying charge from one point to another.
- Rate of this work is power. $P = VI$, this power is wasted in form of heat.
- Power lost in connecting wires is given by
- $P_C = \frac{P^2 R_c}{V^2}$

P = Power to be delivered

R_c = resistance of connecting wires

V = Potential difference b/w ends of conductor.

We see $P_C \propto \frac{1}{V^2}$ for this reason long distance transmission is done at “high voltage low current

- House hold electricity –all devices are connected in parallel.
- Failure of one device does not affect working of the other device.
- All devices are at the same potential difference
- In parallel, the equivalent resistance is very small so heat losses (energy losses) reduces.
- Resistance of a device is always constant because it is fixed by the manufacturer
- A bulb rated as 100W-220 V means the bulb will dissipate (consume) 100 W of electrical power when subjected to 220V. If it is subjected to 110 V, it will dissipate less power.

- Resistance of this bulb is given by $P = \frac{V^2}{R}$
- A high wattage device has smaller resistance than a device of low wattage.
- Rated power is the marked power on the device when subjected to a particular voltage.
- Instantaneous power is the power dissipated at a given instant of time or situation.