

1. Details of Module and its structure

Module Detail	
Subject Name	Physics
Course Name	Physics 03 (Physics Part 1 Class XII)
Module Name/Title	Unit-01, Module-09: Capacitance Chapter-02: Electrostatic Potential and Capacitance
Module Id	Leph_10203_eContent
Pre-requisites	Electrostatic force, Coulomb's laws of electrostatics, Electrostatic potential and potential difference, Superposition principle
Objectives	<p>After going through this lesson, the learners will be able to</p> <ul style="list-style-type: none"> • Understand ways to increase, the ability of a conductor, to hold, or store, more charge and the idea of a capacitor. • Know the factors that affect the capacitance of a parallel plate capacitor. • Calculate equivalent capacitance obtained by connecting the capacitors, in series, or in parallel, or in a mixed combination • Apply results of finding equivalent capacitors to circuits
Keywords	Electric charge, Electrostatic force, Electric field, Electric potential, electric potential difference, Capacitance, Capacitors, Common potential, Permittivity capacitors in series , capacitors in parallel

2. Development Team

Role	Name	Affiliation
National MOOC Coordinator (NMC)	Prof. Amarendra P. Behera	Central Institute of Educational Technology, NCERT, New Delhi
Programme Coordinator	Dr. Mohd Mamur Ali	Central Institute of Educational Technology, NCERT, New Delhi
Course Coordinator / PI	Anuradha Mathur	Central Institute of Educational Technology, NCERT, New Delhi
Subject Matter Expert (SME)	Pushpa Vati Tyagi	Retired (Kendriya Vidyalaya Sangathan)
Review Team	Associate Prof. N.K. Sehgal (Retd.)	Delhi University
	Prof. V. B. Bhatia (Retd.)	Delhi University
	Prof. B. K. Sharma (Retd.)	DESM, NCERT, New Delhi

Table of Content

1. Unit Syllabus
2. Module wise distribution
3. Words you must know
4. Introduction
5. Capacitance of a conductor
6. Capacitance of an isolated spherical conductor
7. Method of increasing capacitance of a conductor
8. Capacitor and capacitance
9. Principle of a capacitor
10. Series grouping of capacitors
11. Parallel grouping of capacitors
12. Redistribution of charges and common potential
13. Summary

1. UNIT SYLLABUS**Chapter-1: Electric Charges and Fields**

Electric Charges; Conservation of charge, Coulomb's law-force between two point charges, forces between multiple charges; superposition principle and continuous charge distribution.

Electric field, electric field due to a point charge, electric field lines, electric dipole, electric field due to a dipole, torque on a dipole in uniform electric field.

Electric flux, statement of Gauss's theorem and its applications to find field due to infinitely long straight wire, uniformly charged infinite plane sheet and uniformly charged thin spherical shell (field inside and outside).

Chapter-2: Electrostatic Potential and Capacitance

Electric potential, potential difference, electric potential due to a point charge, a dipole and system of charges; equipotential surfaces, electrical potential energy of a system of two point charges and of electric dipole in an electrostatic field.

Conductors and insulators, free charges and bound charges inside a conductor. Dielectrics and electric polarization, capacitors and capacitance, combination of capacitors in series and in parallel, capacitance of a parallel plate capacitor with and without dielectric medium between the plates, energy stored in a capacitor.

2. MODULE WISE DISTRIBUTION OF UNIT SYLLABUS

The above unit is divided into 11 modules for better understanding. **11 Modules**

Module 1	<ul style="list-style-type: none"> • Electric charge • Properties of charge • Coulombs' law • Characteristics of coulomb force • Constant and the intervening medium • numerical
Module 2	<ul style="list-style-type: none"> • forces between multiple charges • superposition • continuous distribution of charges • numerical
Module 3	<ul style="list-style-type: none"> • Electric field E • Importance of field and ways of describing field • Point charges superposition of electric field • numerical
Module 4	<ul style="list-style-type: none"> • electric dipole • electric field of a dipole • charges in external field • dipole in external field Uniform and non-uniform
Module 5	<ul style="list-style-type: none"> • Electric flux , • Flux density • Gauss theorem • Application of gauss theorem to find electric field • For a distribution of charges • Numerical

Module 6	<ul style="list-style-type: none"> • application of Gauss theorem Field due to field infinitely long straight wire • Uniformly charged infinite plane • Uniformly charged thin spherical shell (field inside and outside) • Graphs
Module 7	<ul style="list-style-type: none"> • Electric potential, • Potential difference, • Electric potential due to a point charge, a dipole and system of charges; • Equipotential surfaces, • Electrical potential energy of a system of two point charges and of electric dipole in an electrostatic field. • Numerical
Module 8	<ul style="list-style-type: none"> • Conductors and insulators, • Free charges and bound charges inside a conductor. • Dielectrics and electric polarization
Module 9	<ul style="list-style-type: none"> • Capacitors and capacitance, • Combination of capacitors in series and in parallel • Redistribution of charges , common potential • numerical
Module 10	<ul style="list-style-type: none"> • Capacitance of a parallel plate capacitor with and without dielectric medium between the plates • Energy stored in a capacitor
Module 11	<ul style="list-style-type: none"> • Typical problems on capacitors

MODULE 9**3. WORDS YOU MUST KNOW**

Let us remember the words we have been using in our study of this physics course.

- **Electric Charge:** Electric charge is an intrinsic characteristic, of many of the fundamental particles of matter that gives rise to all electric and magnetic forces and interactions.
- **Conductors:** Some substances readily allow passage of electricity through them, others do not. Those which allow electricity to pass through them easily are called *conductors*. They have electric charges (electrons) that are comparatively free to move inside the material. Metals, human and animal bodies and earth are all conductors of electricity.
- **Insulators:** Most of the non-metals, like glass, porcelain, plastic, nylon, wood, offer high opposition to the passage of electricity through them. They are called *insulators*.
- **Point Charge:** When the linear size of charged bodies is much smaller than the distance separating them, the size may be ignored and the charge bodies can then be treated as *point charges*.
- **Coulomb's Force:** It is the electrostatic force of interaction between the two point charges.
- **Linear charge density:** The linear charge density λ is defined as the charge per unit length.
- **Surface charge density:** The surface charge density σ is defined as the charge per unit surface area.
- **Volume charge density:** The volume charge density ρ is defined as the charge per unit volume.
- **Superposition Principle:** For an assembly of charges q_1, q_2, q_3, \dots , the force on any charge, say q_1 , is the vector sum of the force on q_1 due to q_2 , the force on q_1 due to q_3 , and so on. For each pair, the force is given by the Coulomb's law for two point charges.
- **Electric Field:** A region around a charge particle or object within which a force would be experienced by charge particle or object.

- **Source and test charge:** The charge, which is producing the electric field, is called a *source charge* and the charge, which tests the effect of as source charge, is called a *test charge*.
- **Uniform Field:** A *uniform electric field* is one whose magnitude and direction is same at all points in space and it will exert same force of a charge regardless of the position of charge.
- **Non uniform field:** we know that electric field of point charge depends upon location of the charge. Hence has different magnitude and direction at different points. We refer to this field as non-uniform electric field
- **Principle of superposition of fields:** Electric field intensity E at any point P due to all n point charges will be equal to the vector sum of electric field intensities $E_1, E_2, E_3, \dots, E_n$ produced by individual charges at the point P . Hence $E = E_1 + E_2 + \dots + E_n$
- **Torque:** Torque is the tendency of a force to rotate an object about an axis.
- **Electric field lines:** An electric field line is a curve drawn in such a way that the tangent at each point on the curve gives the direction of electric field at that point.
- **Surface charge density in terms of area element:** The surface charge density σ at the area element Δs is given by $\sigma = \frac{\Delta Q}{\Delta s}$
- **Area vector:** The area element vector ΔS at a point on a closed surface equals $\Delta S \hat{n}$ where ΔS is the magnitude of the area element and \hat{n} is a unit vector in the direction of outward normal at that point.
- **Gaussian surface:** The closed surface that we need to choose for applying Gauss's law to a particular charge distribution is called the Gaussian surface.
- **Gauss's law:** The flux of the electric field through any closed surface S is $1/\epsilon_0$ times the total charge enclosed by that surface.
- **Electrostatic force:** Like charges repel each other and unlike charges attract each other, this force of attraction, or repulsion, between two charges, is called electrostatic force.
- **Coulomb's Law of electrostatics:** The force of attraction, or repulsion, between two point charges, is directly proportional to the product of the magnitude of the two charges and inversely proportional to the square of the distance between them. The force acts along the line joining the two charges.

- **Electrostatic potential:** It is the amount of work done in moving a unit positive charge, from infinity to that point, in the electric field, without accelerating it.
- **Principle of superposition:** If we have a collection of point charges, the force on any one of them, is the vector sum of the electrostatic forces exerted by all the other point charges.

4. INTRODUCTION:

When an insulated conductor is given some charge, it acquires a certain potential. If the charge on the conductor is increased its potential also increases.

We will consider how much charge can be given to a conductor? Is there a limit to the amount of charge that a conductor can store? We will study methods to increase the ability of a conductor, to store charge.

5. CAPACITANCE OF A CONDUCTOR:-

When an insulated conductor is given some charge, it acquires a certain potential. If the charge on the conductor is increased, its potential also increases.

If Q is the charge given to an insulated conductor and V is the potential to which it is raised, then,

$$Q \propto V$$

$$\text{or } Q = CV$$

The constant of proportionality is called the *capacitance of the conductor*.

$$C = \frac{Q}{V}$$

If $V = 1V$ then $C = Q$

Thus the electrical capacitance of a conductor is the measure of its ability to hold electric charge.

The capacitance is defined as the charge required to increasing the potential of the conductor by 1V.

S.I. unit of capacitance

If $Q = 1C, V = 1V$

$$\text{Then } C = \frac{Q}{V} = \frac{1C}{1V} = 1CV^{-1}$$

$$= 1 \text{ Farad}$$

$$= 1 F$$

S.I. unit of capacitance is 1 Farad.

The capacitance of a capacitor is said to be 1Farad if the charge of 1 Coulomb given to it raises the potential of the conductor by 1 Volt.

EXAMPLE: What do you think will happen to the

- i) Potential
- ii) Capacitance, of a conductor if the amount of charge on it is doubled?

SOLUTION

i) Potential will also double as the potential of a conductor is directly proportional to the charge given.

ii) Capacitance will not change

EXAMPLE:

What will be the expected nature of graph if charge given to a conductor, is plotted on x axis and the potential to which it is raised, on y axis and how will you find, capacitance from this graph?

SOLUTION

Graph will be a straight line.

The reciprocal of slope of the line will give capacitance.

6. CAPACITANCE OF AN ISOLATED SPHERICAL CONDUCTOR:

Let us consider an isolated spherical conductor of radius r and charge q is uniformly distributed all over its surface. The potential V at any point on the surface of the conductor is given by

$$V = \frac{Q}{4\pi\epsilon_0 r}$$

Thus the capacitance $C = q/V = 4\pi\epsilon_0 r$

We find that the capacitor, of an isolated spherical capacitor, is directly proportional to, its radius

$$C \propto r$$

Capacitance of a conductor depends upon:

- (i) Size and shape of the conductor
- (ii) Nature of the surrounding medium.
- (iii) Presence of other conductors in its neighborhood

Now let us calculate the radius of a spherical conductor whose capacitance is 1F

$$r = 1/(4\pi\epsilon_0 C) = 9 \times 10^9 \times 1 = 9 \times 10^9 \text{ m}$$

This radius is nearly 1500 times the radius of earth, thus we conclude that

1 Farad is a very large unit of capacitance and the capacitance of conductors of the size that can be handled is very small.

Also when a conductor holds a large amount of charge, its potential becomes very high. If the associated electric field becomes high enough, the atoms or molecules, of the surrounding medium get ionized and the charge placed on the conductor, gets neutralized. Thus there is a limit on the amount of charge a conductor can hold. That limit depends on the potential that it acquires when certain charge is put on it.

Now we will study ways to increase the capacity or ability of a conductor to have more charge, and yet not go to the limit where its potential is high enough to cause the atoms/molecules, of the surrounding medium, to get ionized.

7. METHOD OF INCREASING CAPACITANCE OF A CONDUCTOR: -

Capacitance of a conductor can be increased by placing an uncharged conductor closed to it and connecting the uncharged conductor to earth.

The device so formed is called a capacitor.

8 CAPACITOR AND CAPACITANCE :

The ability of a conductor, to hold charge can be increased by placing an uncharged conductor closed to it, and connecting the uncharged conductor, to earth. The device so formed is called a capacitor. So capacitor is an assembly of two conductors separated by an insulating medium and it is used to store electric energy by accumulating charge on the conductors.

9. PRINCIPLE OF A CAPACITOR:-

Consider a positively charged metal conductor, A, and place an uncharged conductor, B, close to it, as shown in the figure below. Due to induction, the closer face of conductor B acquires a negative charge and its farther face acquires a positive charge. The negative charge on conductor B tends to reduce the potential on conductor A, while the positive charge, on conductor B, tends to increase the potential on A. As the negative charge, of conductor plate B, is closer to conductor A, than its positive charge, so the net effect is that the potential of A is decreased by a small amount, and hence, the charge needed to raise its potential, to a given value increases by a small amount.

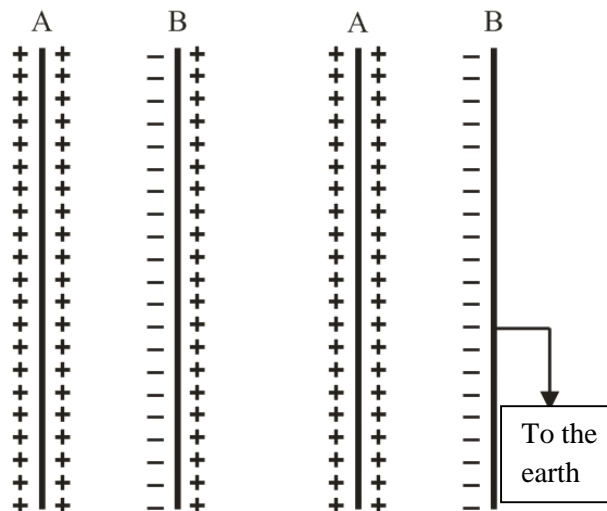

Figure: Principle of a capacitor

Now if the positive face of plate B is earthed, its positive charge gets neutralized due to the flow of electrons from the earth to the plate B. The negative charge, on B, is held in position due to the positive charge on A. The negative charge on B reduces the potential of A considerably and hence increases the magnitude of charge that would increase its potential by a given value by a large amount.

Hence we see that the ability, of an isolated conductor, to store charge, is considerably increased when we place an earthed connected conductor near it. Such a system of two conductors is called a capacitor.

So capacitor is an assembly of two conductors separated by an insulating medium and it is used to store electric energy by accumulating charge on the conductors.

The two conductors have equal and, opposite charges, $+Q$ and $-Q$, and there is a potential difference, V , between the conductors.

If Q is the magnitude of the charge, given to either plate of the capacitor, and V is the potential difference between its two plates it is known that, the magnitude of the charge Q , is directly proportional to potential difference between the two conductors,

$$Q \propto V$$

$$\text{or } Q = CV$$

The constant of proportionality is called the *capacitance of the capacitor*.

$$C = \frac{Q}{V}$$

If $V = 1\text{ Volt}$, $C = Q$

Thus the (electrical) capacitance, of a capacitor, (which may be viewed as a measure of its ability to hold electric charge) *is defined as* **“the charge required to increase the potential difference between the plates of the capacitor by a unit amount”**.

S.I. unit of capacitance

If $Q = 1\text{ C}$, $V = 1\text{ V}$

$$\begin{aligned} \text{then, } C &= \frac{Q}{V} = \frac{1\text{ C}}{1\text{ V}} = 1\text{ CV}^{-1} \\ &= 1 \text{ farad} \\ &= 1 \text{ F} \end{aligned}$$

S.I. unit of capacitance is 1farad.

The capacitance of a capacitor is said to be 1farad if the charge of 1 C given to it raises the potential difference between the plates by 1 volt.

Compare this to the statement for one farad as stated earlier in the module .

In practice, 1farad is a very big unit. The more common units are its sub multiples.

$$1 \text{ microfarad} = 1\mu\text{F} = 10^{-6}\text{ F}$$

$$1 \text{ nanofarad} = 1\text{nF} = 10^{-9}\text{ F}$$

$$1 \text{ picofarad} = 1\text{pF} = 10^{-12}$$

Dimensional formula of capacitance is $\text{M}^{-1}\text{L}^{-2}\text{T}^4\text{A}^2$

CHARGING OF CAPACITORS:-

When a capacitor is connected across a battery, electrons flow from the negative terminal of the battery to the plate of the capacitor connected to that terminal. At the same time, electrons flow from the other plate of the capacitor, to the positive terminal of the battery. This gives a flow of current, when the capacitor is being charged.

As the charges accumulate on the plates of the capacitor, an electric potential difference gets built between the plates. This hinders further accumulation of charges and makes the charging current decrease. When the P.D. between the plates, equals the potential of the battery, the current becomes zero.

Charge stored in a capacitor = Magnitude of charge on any one plate

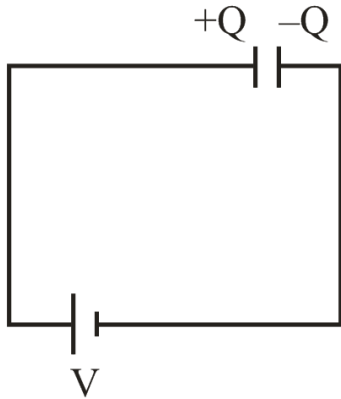

Where the total charge, on the capacitor

$$= (+Q) + (-Q) = 0$$

For video refer to the video: –

<https://www.youtube.com/watch?v=5D2cLj28Pc8>

<https://www.khanacademy.org/science/physics/circuits-topic/circuits-with-capacitors/v/capacitors-and-capacitance>

For video on capacitor: <https://www.youtube.com/watch?v=u-jigaMJT10>

COMBINATION OF CAPACITORS:

A number of capacitors can be combined suitably, to get the required capacitance.

Two simple ways, of grouping of capacitors are

- (1) Series grouping
- (2) Parallel grouping

10. SERIES GROUPING OF CAPACITORS

The capacitors are said to be connected in series, if charge can move, from one point to another in the circuit, only through one path.

The figure shows three capacitors, C_1 , C_2 and C_3 , connected in series

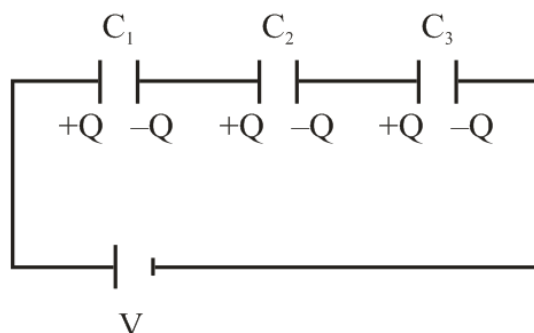

When a Potential difference V is applied across this combination, the battery supplies charge: $(-Q)$ to the right hand side plate of C_3 , by induction $+Q$ appears on the left hand side plate of C_3 and $(-Q)$ flows to right hand side plate of C_2 and so on, hence, in this process, each plate receives the same charge 'Q' of the same magnitude.

So, in series combination the charge on each capacitor is same. As their capacitance is different, so the potential difference, across each capacitor is different.

$$\text{The P.D. across } C_1 = V_1 = \frac{Q}{C_1}$$

$$\text{The P.D. across } C_2 = V_2 = \frac{Q}{C_2}$$

$$\text{The P.D. across } C_3 = V_3 = \frac{Q}{C_3}$$

The total potential drop V , across the combination, is the sum of potential drops V_1 , V_2 and V_3 across, C_1 , C_2 and C_3 .

$$\begin{aligned} V &= V_1 + V_2 + V_3 \\ &= \frac{Q}{C_1} + \frac{Q}{C_2} + \frac{Q}{C_3} = Q \left[\frac{1}{C_1} + \frac{1}{C_2} + \frac{1}{C_3} \right] \quad \dots\dots(1) \end{aligned}$$

If the combination is replaced by a single capacitor of capacitance C_s , which acquires the same charge Q , as is acquired by the combination, then C_s is called the equivalent capacitance of the combination. So,

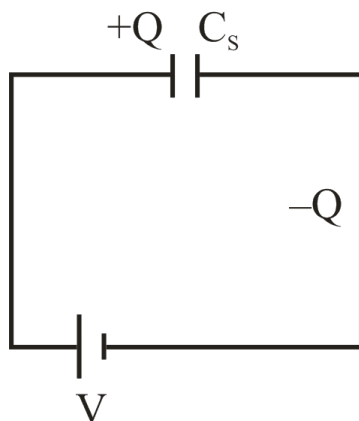

$$V = \frac{Q}{C_s} \dots\dots\dots (2)$$

Comparing equation (1) and (2) we get

$$\frac{Q}{C_s} = Q \left[\frac{1}{C_1} + \frac{1}{C_2} + \frac{1}{C_3} \right]$$

$$\frac{1}{C_s} = \frac{1}{C_1} + \frac{1}{C_2} + \frac{1}{C_3} \dots\dots\dots (3)$$

For 'n' capacitors following the same steps, as for the case of three capacitors, we get the general formula.

$$\frac{1}{C_s} = \frac{1}{C_1} + \frac{1}{C_2} + \dots + \frac{1}{C_n} \dots\dots\dots (4)$$

If all n capacitors are identical then

$$\frac{1}{C_s} = \frac{1}{C} + \frac{1}{C} + \dots n \text{ times}$$

$$\frac{1}{C_s} = \frac{n}{C}$$

$$\text{or } C_s = \frac{C}{n} \dots\dots\dots (5)$$

POINTS TO REMEMBER:

- (i) The reciprocal of the equivalent capacitance of a series combination, is equal to the sum of the reciprocals of the individual capacitances.
- (ii) The charge, on each capacitor, in a series combination is the same.
- (iii) The equivalent capacitance is smaller than the smallest of the individual capacitances.
- (iv) If n identical capacitors, of capacitance C , each are connected in series, their equivalent capacitor is $\frac{C}{n}$.

For video on series combination of capacitors refer to the video:-
<https://www.khanacademy.org/science/physics/circuits-topic/circuits-with-capacitors/v/capacitors-series>

EXAMPLE

Three capacitors each of 9pF are connected in series. The combination is connected to a 120 V power supply?

- (i) **What is the total capacitance of the combination?**
- (ii) **What is the charge on each capacitor?**
- (iii) **What is the potential difference across each capacitor of the combination?**

SOLUTION:

(i) As capacitors are connected in series

$$\frac{1}{C} = \frac{1}{C_1} + \frac{1}{C_2} + \frac{1}{C_3}$$

$$\frac{1}{C} = \frac{1}{9} + \frac{1}{9} + \frac{1}{9} = \frac{3}{9} = \frac{1}{3}$$

$$C = 3pF$$

(ii) In series combination, charge on each capacitor, is equal, and it is equal to the charge drawn from the battery.

$$Q_1 = Q_2 = Q_3 = Q = CV = (3 \times 10^{-12}) \times 120 \text{ C}$$

$$= 360 \times 10^{-12} \text{ C}$$

$$(iii) Q_1 = C_1 V_1$$

$$\text{So } V_1 = \frac{Q_1}{C_1}$$

$$V_1 = \frac{360 \times 10^{-12}}{9 \times 10^{-12}} \text{ V} = 40 \text{ V}$$

$$V_2 = \frac{Q_2}{C_2} = \frac{360 \times 10^{-12}}{9 \times 10^{12}} \text{ V} = 40 \text{ V}$$

$$V_3 = \frac{Q_3}{C_3} = \frac{360 \times 10^{-12}}{9 \times 10^{12}} \text{ V} = 40 \text{ V}$$

EXAMPLE

The equivalent capacitance, of the combination between A and B in figure given below is $4\mu\text{F}$.



- Calculate the capacitance of the capacitor C.
- Calculate the charge on each capacitor if a 10V battery is connected across the terminals A and B.
- What will be the potential drop across each capacitor?

SOLUTION:

$$(a) \quad C_1 = 20\mu\text{F}, \quad C_2 = C$$

C_1 and C_2 are connected in series

$$\frac{1}{4} = \frac{1}{20} + \frac{1}{C}$$

$$\frac{1}{C} = \frac{1}{4} - \frac{1}{20} = \frac{5-1}{20} = \frac{4}{20}$$

$$\text{So } C = \frac{20}{4} = 5\mu F$$

(b) Charge on each capacitor

$$q = C_{AB}V = 4 \times 10^{-6} \times 10C = 40 \times 10^{-6}C$$

(c) P.D. across $20\mu F$ capacitor $= \frac{q}{C} = \frac{40 \times 10^{-6}}{20 \times 10^{-6}}V = 2V$

P.D. across $5\mu F$ capacitor $= \frac{q}{C} = \frac{40 \times 10^{-6}}{5 \times 10^{-6}}V = 8V$

11. PARALLEL COMBINATION OF CAPACITORS:

Capacitors are said to be connected in parallel between two points, if charges can move from one point to another, along different paths.

Here, the positive plates, of all the capacitors, are connected to one common point and the negative plates are connected to another common point.

The potential difference, across each capacitor, is same while the charge gets divided, depending upon the capacitance of the capacitors.

Figure shows three capacitors, of capacitance, C_1 , C_2 and C_3 , connected in parallel. A potential difference, V , is applied across the combination. All the capacitors have a common potential difference, V , but different charges, given by

$$Q_1 = C_1V, \quad Q_2 = C_2V, \quad Q_3 = C_3V$$

Total charge stored in the combination, is

$$Q = Q_1 + Q_2 + Q_3 = (C_1 + C_2 + C_3)V \quad \dots\dots\dots(1)$$

If C_p is the equivalent capacitance of the parallel combination, then

$$Q = C_pV \quad \dots\dots\dots(2)$$

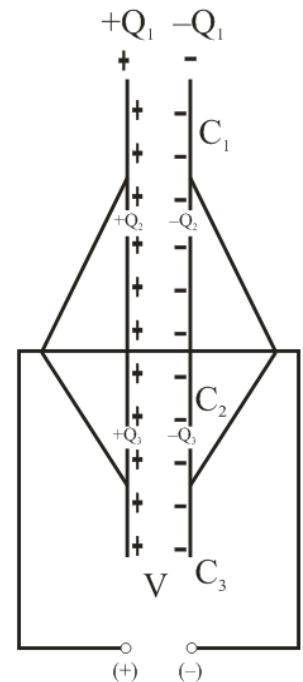
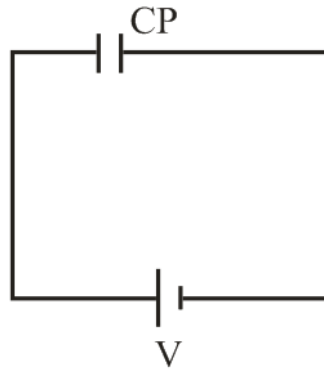

Figure: Capacitors in parallel



From equations (1) and (2), we get

$$C_p V = (C_1 + C_2 + C_3)V$$

$$C_p = C_1 + C_2 + C_3$$

For a parallel combination of n capacitors, we can write

$$C_p = C_1 + C_2 + \dots C_n$$

FOR PARALLEL COMBINATION OF CAPACITORS

1. The equivalent capacitance is equal to the sum of the individual capacitances.
2. The equivalent capacitance is larger than the largest of the individual capacitances.
3. The potential difference across each capacitor is same.
4. The charge on each capacitor is proportional to its capacitance.

Video on parallel grouping of capacitors

<https://www.khanacademy.org/science/physics/circuits-topic/circuits-with-capacitors/v/capacitors-parallel>

EXAMPLE:

Calculate the (i) charge supplied by the battery in the circuit shown below

(ii) Also calculate the charge on each capacitor

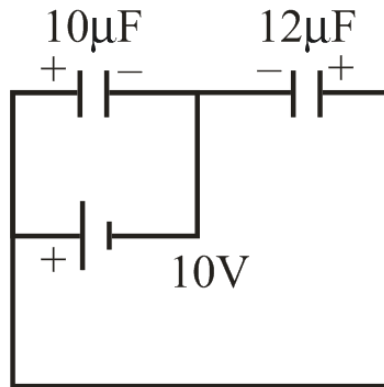
**SOLUTION:**

The given arrangement is equivalent to

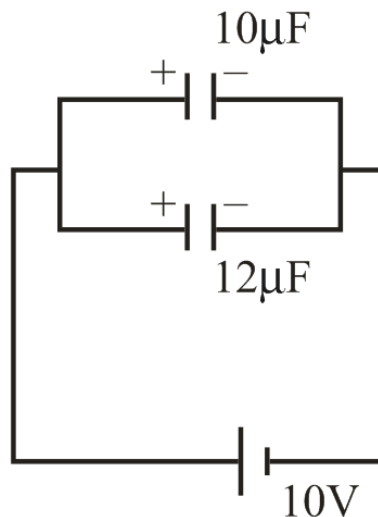

Let $C_1 = 10\mu F$, $C_2 = 12\mu F$

They are connected in parallel

So $C = C_1 + C_2$

$$= (10 + 12)\mu F = 22\mu F$$

(i) Charge supplied by the battery

$$q = CV = 22 \times 10^{-6} \times 10$$

$$= 220 \times 10^{-6} C$$

(ii) Charge on $C_1 = q_1 = C_1 V = 10 \times 10^{-6} \times 10 C$

$$= 1 \times 10^{-4} C$$

$$\begin{aligned} \text{Charge on } C_2 = q_2 &= C_2 V = 12 \times 10^{-6} \times 10 \text{ C} \\ &= 120 \times 10^{-6} C \end{aligned}$$

12. REDISTRIBUTION OF CHARGES & COMMON POTENTIAL:-

When two capacitors, charged to different potentials are connected by a conducting wire, charges flow, from the one at higher potential, to the other, at a lower potential. This flow of charge continues till they attain same potential. The equal potential of the two capacitors is called their *common potential*. In this process, there is only a sharing of the charges by two capacitors, and no charge is lost in the process.

Expression for common potential:-

Let C_1 and C_2 be the capacitances of the two capacitors charged to the potentials of V_1 and V_2 respectively.

$$Q_1 = C_1 V_1, \quad Q_2 = C_2 V_2$$

Total charge before sharing

$$Q = Q_1 + Q_2 = C_1 V_1 + C_2 V_2$$

If V is the common potential attained on sharing charges then total charge after sharing = $C_1 V + C_2 V$.

As no charge is lost, we have

$$C_1 V_1 + C_2 V_2 = C_1 V + C_2 V$$

$$(C_1 + C_2)V = C_1 V_1 + C_2 V_2$$

$$V = \frac{C_1 V_1 + C_2 V_2}{C_1 + C_2}$$

EXAMPLE

(a) A 900 pF capacitor is charged by 100 V battery Fig. How much electrostatic energy is stored by the capacitor? (b) The capacitor is disconnected from the battery and connected to another 900 pF capacitor. What is the Common potential of the assembly?

SOLUTION

The charge on the capacitor is $Q = CV = 900 \times 10^{-12} \text{ F} \times 100 \text{ V} = 9 \times 10^{-8} \text{ C}$

$$V = \frac{C_1 V_1 + C_2 V_2}{C_1 + C_2}$$

$$V = \frac{900 \times 100 + 0}{900 + 900} = 50 \text{ V}$$

13. SUMMARY

- Potential of a conductor increases with increase in charge given to it
- Ratio of charge to potential is constant and is the measure of its capacitance
- Si unit of capacitance is Farad
- Farad is a very big unit
- Capacitance of an isolated spherical conductor is proportional to its radius
- The capacitance of the conductors which can be handled conveniently is very small
- The capacitance of a conductor can be increased by keeping an uncharged conductor close to it and connecting it to earth
- Capacitors can be combined in series or parallel or in mixed grouping to get the required capacitance
 - in series combination
 - i) the charge on each capacitor is same
 - ii) The reciprocal of equivalent capacitance of a series combination is equal to the sum of the reciprocals of the individual capacitances
 - iii) The equivalent capacitance is smaller than the smallest individual capacitance.

iv) If n identical capacitors of capacitance C each are connected in series then equivalent capacitor is $\frac{C}{n}$. Potential difference across each capacitor is V/n where V is the voltage applied across the combination.

- In parallel grouping

i) The equivalent capacitance is equal to the sum of the individual capacitances.

ii) The equivalent capacitance is larger than the largest individual capacitance.

iii) The potential difference across each capacitor is same.

iv) The charge on each capacitor is proportional to its capacitance.

- When conductors charged to different potential are connected then charge will flow from a body at higher potential to the one at lower potential till both reach at the same potential called common potential.